

KUBAIR® F400 ECOWATT®

Smoke extract unit F400 - 120 (400°C 120 min)

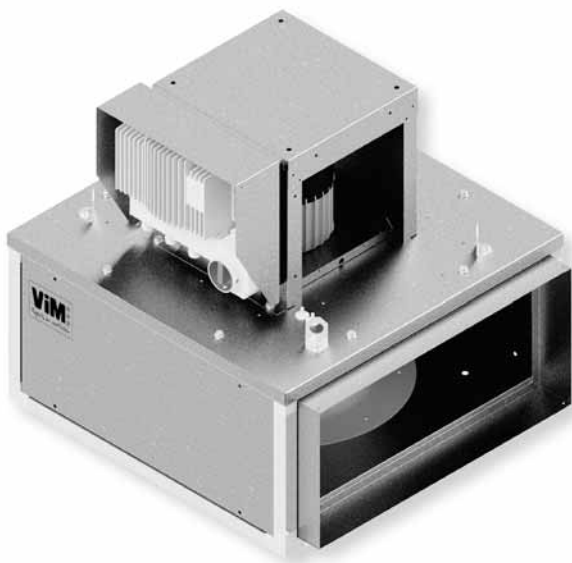

INDICE

1. GENERAL	3
1.1 Disclaimers	3
1.2 Consignes de sécurité	3
1.3 Safety instructions	3
1.4 Acceptance – Storage	3
1.5 Warranty	4
2. PRODUCT PRESENTATION	4
3. INSTALLATION	5
3.1 Dimensions and weight (mm)	5
3.2 Summary charts of assembly and accessories	6
3.3 Accessories (dimensions in mm)	8
3.4 Handling	12
3.5 Casing assembly	12
4. ELECTRICAL CONNECTION	13
4.1 Preliminary precautions	13
4.2 Caractéristiques électriques	13
4.3 Wiring of INTZ safety switch	13
5. COMMISSIONING AND SETTING	14
5.1 Preliminary precautions	14
5.2 Controllers	15
5.3 Operation for smoke extraction	18
5.4 Ventilation fault indication	18
5.5 KUBAIR® F400 ECOWATT® Single-phase - VAV variable flow rate control	19
5.6 KUBAIR® F400 ECOWATT® Single-phase - CAV constant flow rate control	24
5.7 KUBAIR® F400 ECOWATT® Single-phase - COP constant pressure control	26
5.8 KUBAIR® F400 ECOWATT® 3-phases - VAV variable flow rate control	28
5.9 KUBAIR® F400 ECOWATT® 3-phases - CAV constant flow rate control	33
5.10 KUBAIR® F400 ECOWATT® 3-phases - COP constant pressure control	35
6. MAINTENANCE	38
6.1 Maintenance frequency	38
6.2 Spare parts KUBAIR® F400 ECOWATT®	39
7. WASTE MANAGEMENT	40
7.1 Treatment of Packagings and non dangerous wastes	40
7.2 Treatment of a Professional WEEE	40

1. GENERAL

1.1 Disclaimers

This product has been manufactured according to rigorous technical rules of safety in conformity with EC standards. The EC declaration may be downloaded from the Internet site (address given on the last page). Before installing and using this product, carefully read these instructions, which contain important indications for your safety and the user's safety during the installation, commissioning and maintenance of this product. Once the installation is achieved, keep this manual handy nearby the machine for future consultation.

This product must be installed (installation, connections, commissioning, maintenance) and all other interventions performed by a professional applying recognized good practice procedures, and respecting the standards and safety regulations in force. The installation must be made in accordance with the prescriptions indicated in the Electromagnetic Compatibility (EMC) and Low Voltage (LV) Directives.

We advise all people exposed to risks to scrupulously respect the accident prevention standards. The manufacturer may not be held liable for any human injury and/or material damage resulting from the non-respect of the safety instructions or from a change made on the product.

Smoke extract unit KUBAIR® F400 ECOWATT® are intended for smoke extraction and ventilation applications in residential buildings, tertiary buildings, industrial buildings and professional kitchens:

- Outdoor installation
- Environmental temperature range: -10°C / +45°C
- Max temperature of extracted air in permanent operation: 120°C
- Relative humidity: max 95% non-condensing
- Atmosphere not potentially explosive
- Low salinity atmosphere, with no corrosive chemical agents

1.2 Consignes de sécurité

1.3 Safety instructions

- Wear suitable PPE (Personal Protective Equipment) before any intervention.
- Before installing the roof fan and its accessories, make sure that the support and the location are sufficiently resistant to withstand the unit's weight and the accessories, if any.
- Do not remove mesh grilles to access the impeller before cutting off the electric power supply with the safety switch.
- If the work is to be done inside the device, cut off the electric power supply with the main circuit breaker and make sure that nobody can accidentally switch it back on.
- Make sure that moving parts are stopped.
- Make sure that the impeller is not accessible from connection tappings (connection duct or mesh protection).

Before starting, check the following points:

- Make sure that the device does not contain any foreign body.
- Make sure that all the components are attached to their original locations.
- Check manually that the impeller does not rub or is not blocked.
- Make sure that the mesh protection are in place.
- Make sure that the ground connection is connected.

1.4 Acceptance – Storage

In case of missing items or delivery of non conforming, partially or totally damaged products, the Buyer shall make, in accordance with article 133-3 of the French Commercial Code, reservations in writing on the transporter receipt and confirm them within seventy-two (72) hours by registered letter along with a copy addressed to the seller. Should the Buyer fail to make reservations when he receives the equipment, he will not be allowed to make any future claim against us.

The product must be stored protected from the weather, shocks and dirt due to splashings or splatterings of any kind during transport from the supplier to the end customer, and onto the worksite before installation.

1.5 Warranty

The equipment is warranted for twelve (12) months – Parts only – from date of manufacture.



VIM agrees to replace parts or the equipment whose operation is recognised defective by our departments, excluding all damages or penalties, such as operating losses, commercial prejudice, or other intangible or indirect losses.

Our warranty does not cover: (1) defects resulting from an abnormal use or an use not conforming to the recommendations indicated in our manuals; (2) defects observed following normal wear; (3) incidents caused by negligence, lack of monitoring or maintenance; (4) defects due to the inappropriate installation of the devices or unsuitable pre-installation storage conditions.

In any case, VIM may not be held liable for transformed or repaired equipment even partially.

2. PRODUCT PRESENTATION

EC Certificate F400 -120 N° 1812-CPR-0040, according to European Standard NF EN 12101-3
Approved F400 120 (400°C 120 min)

	<ul style="list-style-type: none">• KUBAIR® F400 ECOWATT® CC : complete unit with multi-directional suction plenum, with horizontal or vertical axis motor.
	<ul style="list-style-type: none">• KUBAIR® F400 ECOWATT® MV : single ventilation unit, with horizontal or vertical axis motor.

- 8 sizes : 355 / 400 / 450 / 500 / 630 / 710.
- Flowrates from 500 to 24 000 m³/h.

Construction

- Detachable galvanised steel sheet panels.
- Modular structure of aluminium sections.
- Connection by 2 KUBZ 12 plain flanges which are included.
- High performance galvanised steel reaction turbine, mounted by direct coupling with the motor.

Motor

- ECOWATT® motor, F class, 3 phases with remote IP55 controller :
 - 1 phase 230V 50/60Hz controller input for sizes 355 up to 450.
 - 3 phases 400V 50/60Hz controller input for sizes 500 up to 710.
- Thermal protection fitted within the controller.

Kitchen Option

The kitchen option includes a reinforced seal of the casing and a drain to dispose of wash water. The drain should be installed at the bottom of the casing to allow the wash water to be effectively discharged.

3. INSTALLATION

3.1 Dimensions and weight (mm)

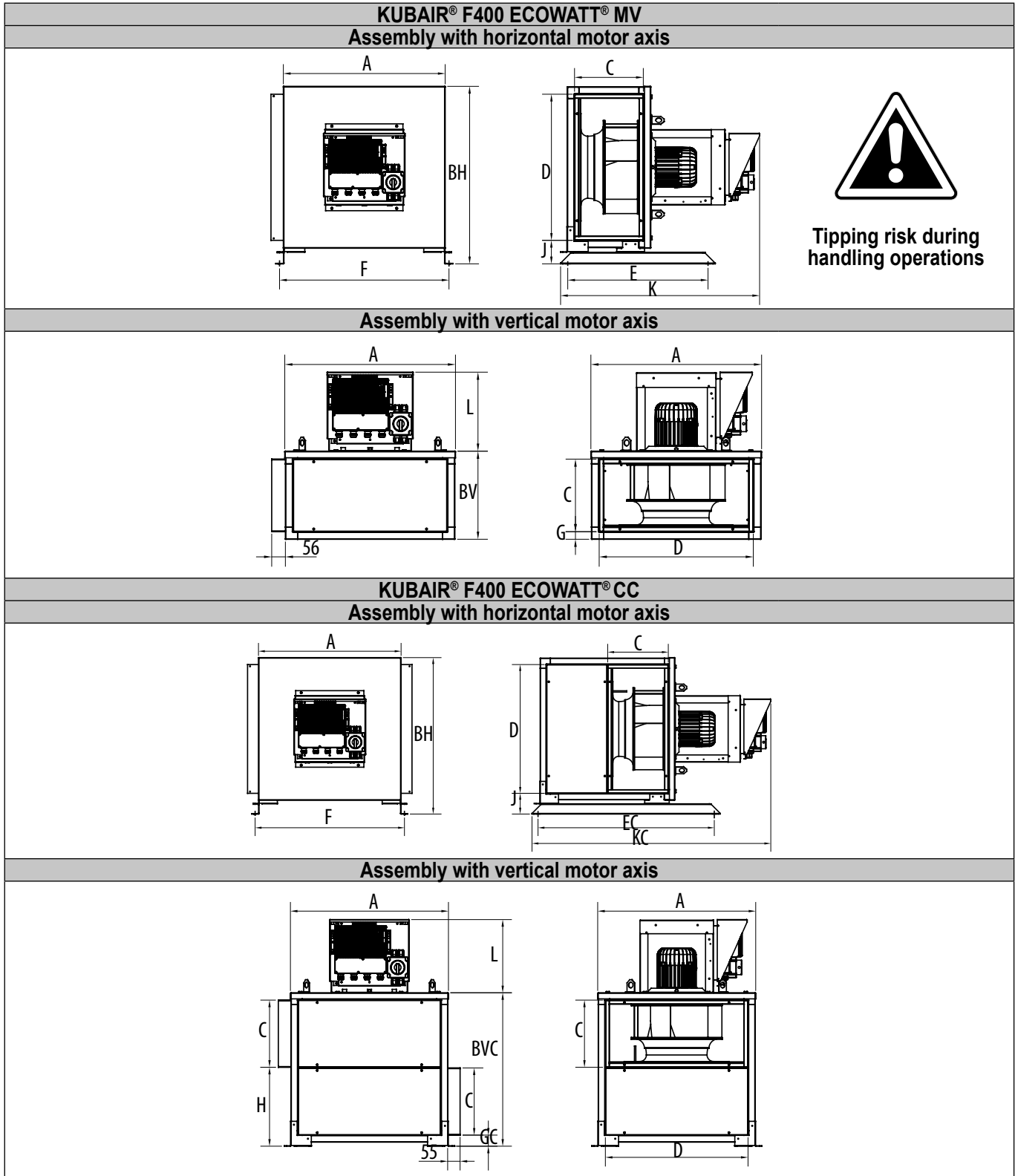

Seize	A	BH	BV	BVC	C	D	E	EC	F	G	GC	H	J	K	KC	L	Weight MV (Kg)		Weight CC (Kg)	
																	Naked	Insulated	Naked	Insulated
355	627	695	327	645	263	559	606	790	660	31	50	315	102	826	1103	321	45	48	65	71
400	699	767	361	678	297	631	606	864	732	31	50	349	102	860	1170	321	56	60	79	87
450	779	847	392	738	326	711	606	990	812	31	50	378	102	892	1230	321	73	78	98	108
500	858	925	424	784	338	768	700	1039	890	42	62	402	112	954	1294	351	94	100	121	132
630	1066	1133	488	912	403	977	700	1183	1098	42	62	466	112	1018	1422	351	133	140	177	195
710	1194	1261	551	1032	462	1104	906	1325	1226	42	62	526	112	1070	1533	446	159	168	279	303

3.2 Summary charts of assembly and accessories

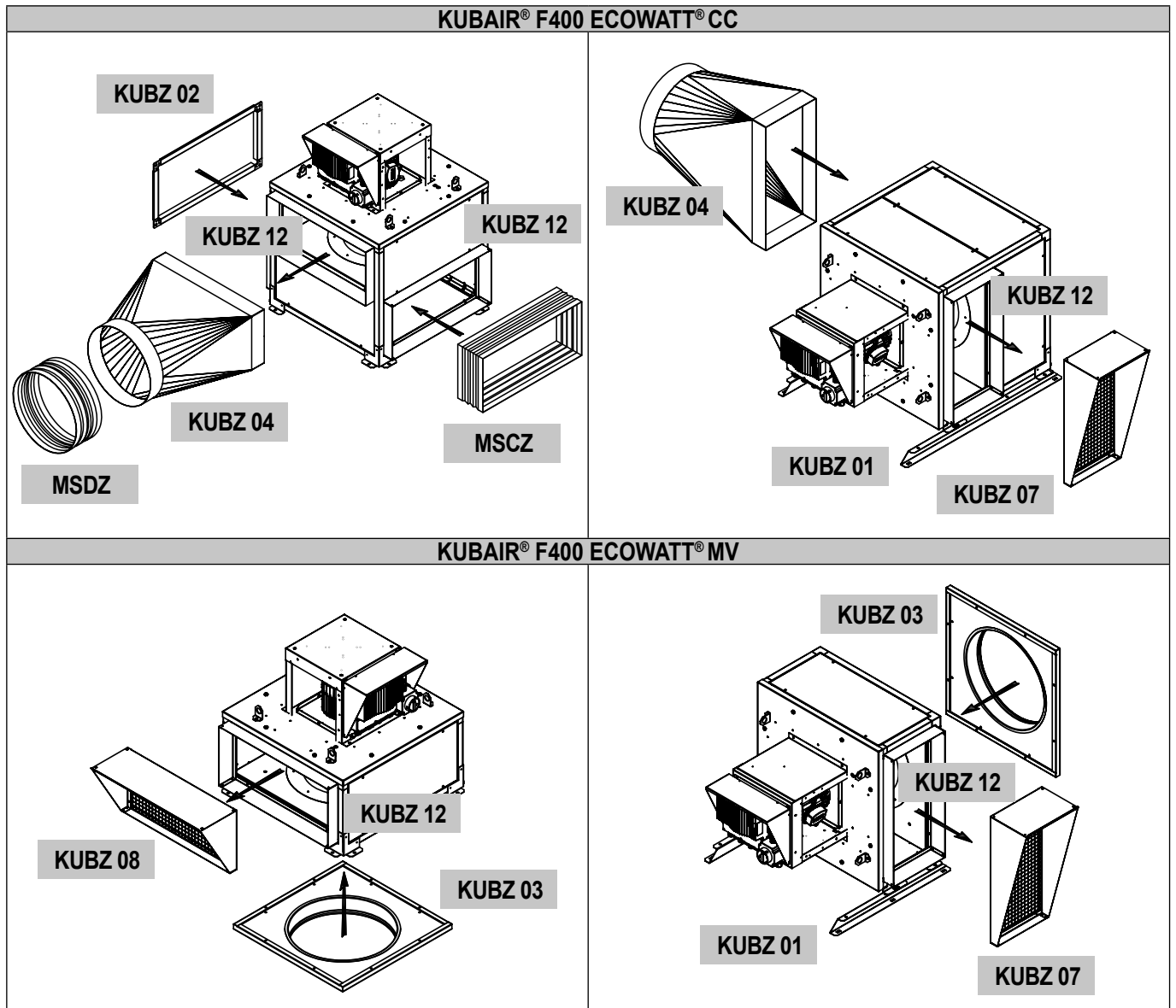

The TCDZ accessories on the diagram below can be used with the KUBAIR® F400 ECOWATT® MV with a vertical axis motor: (example below)

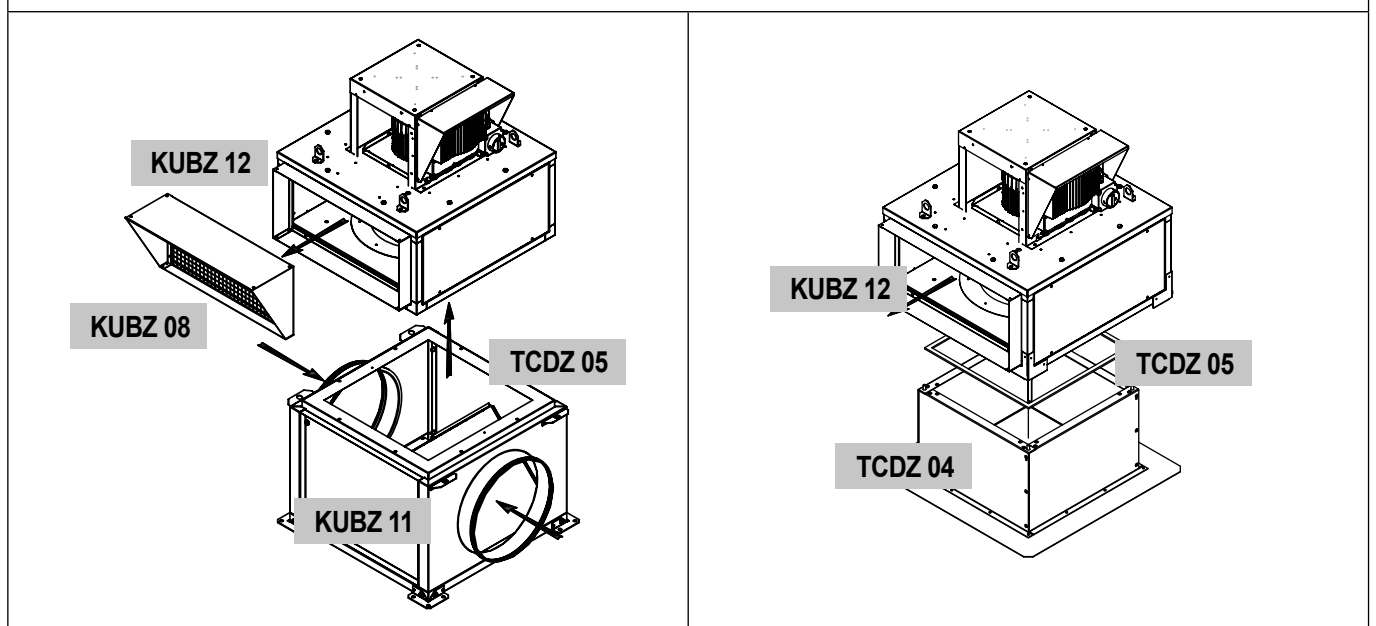

**KUBAIR® F400 ECOWATT® MV
with vertical axis motor**

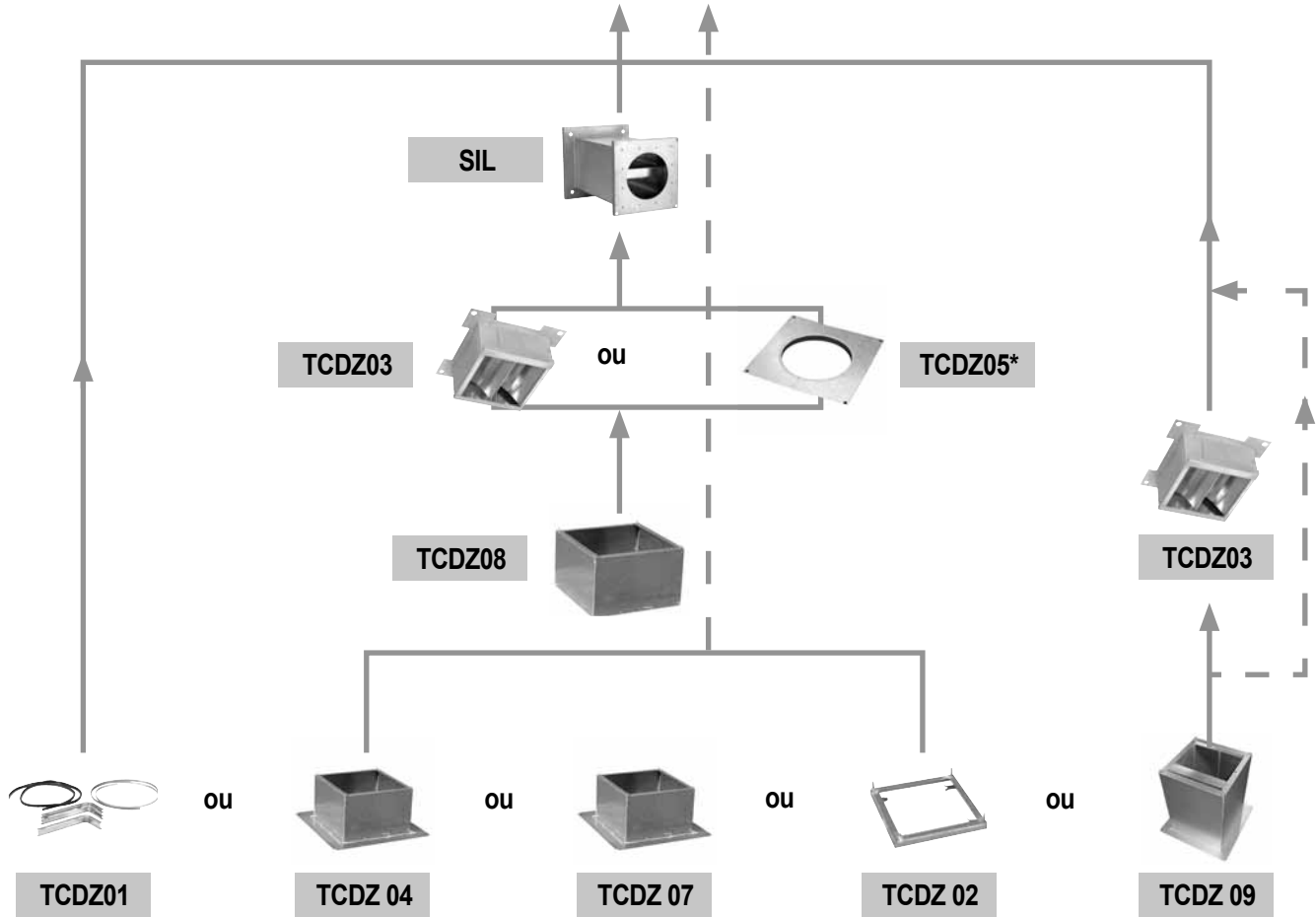
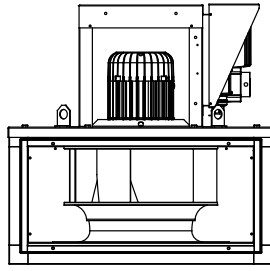

— — — Optional accessory according to selection.

3.3 Accessories (dimensions in mm)

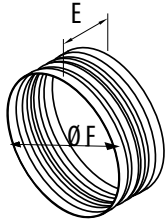
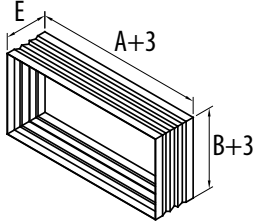
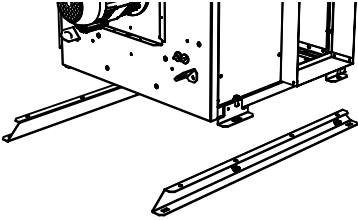
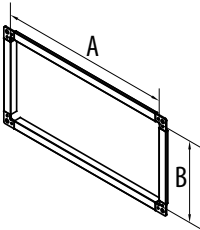
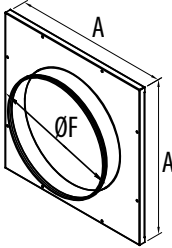
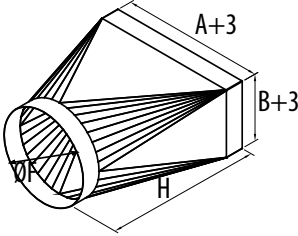
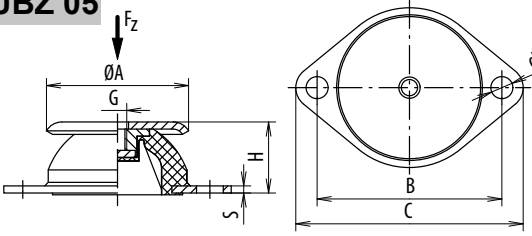
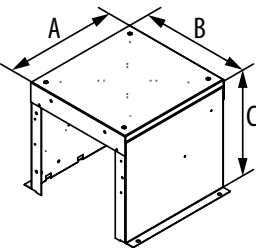
Circular flexible spool piece	Rectangular flexible spool piece
<p>MSDZ</p> 	<p>MSCZ</p> 
<p>KUBZ 01</p> 	<p>Standard support for horizontal axis motor: This support means that the casing can be attached to the floor with the motor in a horizontal position (horizontal axis). The 2 support arms are attached to the casing by the 4 M8 x 15 screws which are supplied, and the 4 stands are attached to the arms by the 16 self-drilling 4.8 x 12 screws which are supplied.</p>
<p>KUBZ 02</p> 	<p>Connecting flange This connecting flange is attached to the plain flange at its 4 corners for the purpose of attaching a sheath.</p>
<p>KUBZ 03</p> 	<p>Circular connection to the MV suction, horizontal axis motor: This connection is used with the KUBAIR® F400 ECOWATT® MV for a sheath connection which does not have an upstand and which does not bear the weight of the casing. The TCDZ 01 allows for this connection by bearing the casing for sizes 355 and 400, vertical axis motor.</p>
<p>KUBZ 04</p> 	<p>Rigid circular connection</p>
<p>KUBZ 05</p> 	<p>Vibration isolating devices 4 vibration isolating devices supplied with 4 screws to attach them to the casing.</p>
<p>KUBZ 06</p> 	<p>Capot KUBAIR® The motor cowl is used for external installations. It is screwed (screws supplied) onto the motor support panel.</p>

KUBZ 07		KUBZ 08		<p>Rain guard with bird guard These guards are attached after the supplied plain flange (KUBZ 12) has been detached from the casing.</p>
KUBZ 11				<p>Double suction plenum To be bolted under the casing, without any accessory between the KUBZ 11 and the casing.</p>
KUBZ 12				<p>Plain flange for pool piece 2 plain flanges are supplied already mounted on the air delivery and suction. Other plain flanges can be supplied and mounted.</p>
KUBZ 15				<p>Covering - horizontal axis motor Assembly of the cover: the cover is attached with 4 (MV version) or 8 (CC version) 4.8 x 12 self-drilling screws which are supplied.</p>

Dimensions (mm) and weight (kg)

MSDZ - MSCZ - KUBZ 02 à 08 - KUBZ 12									Weight					
Model	A	B	C	D	E	ØF	H	J	KUBZ 01	KUBZ 03	KUBZ 04	KUBZ 06	KUBZ 07	KUBZ 08
355	559	263	197	194	160	400	670	80	7,0	2,9	7,5	3,6	1,9	2,0
400	631	297	216	213	160	450	670	80	8,2	3,5	8,5	3,6	2,4	2,4
450	711	326	233	234	160	500	670	80	9,7	4,2	9,6	3,6	2,8	2,8
500	768	338	240	249	160	560	670	80	10,6	4,6	10,5	5,4	3,1	3,1
630	977	403	278	305	160	710	670	80	13,8	6,9	13,2	5,4	4,5	4,3
710	1104	462	311	340	160	800	670	80	17,0	8,3	15,1	6,9	5,6	5,3

Size	KUBZ 05									KUBZ 06		
	A	C	H	G	B	d	S	Screws supplied	A	B	C	
355 to 450	60	90	24	M6	76	62	3	M6x16	340	325	305	
500 and 630	80	120	27	M8	100	82	3	M8x15	415	475	355	
710	100	148	28	M10	124	102	3	M10x15	510	465	450	

Size	KUBZ 11					
	A	B	C	ØD	E	Weight
355	622	448	238	355	662	21
400	694	498	260	400	734	25
450	774	555	289	450	814	30
500	852	675	349	560	892	37
630	1060	805	441	630	1100	81
710	1188	885	481	710	1228	99

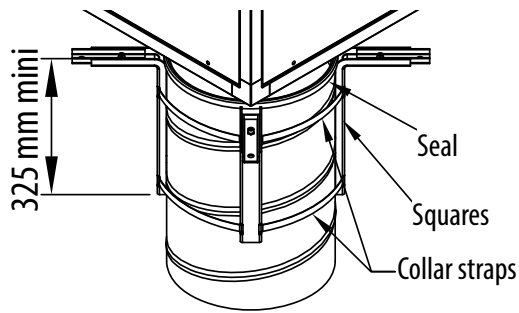
TCDZ 01**Standard support (Sizes 355 ou 400)**

This assembly is not adapted for the use an energy-saving component or an adapter plate. Make sure that the duct can bear the weight of the casing.

- Set up the 4 squares and the 2 collar straps on the duct.
- Set up the seal on the free edge of the duct.
- Put the casing on the duct by correctly placing it in the centre.
- Adjust and assemble the squares on the unit.
- Stretch out the 2 collar straps.

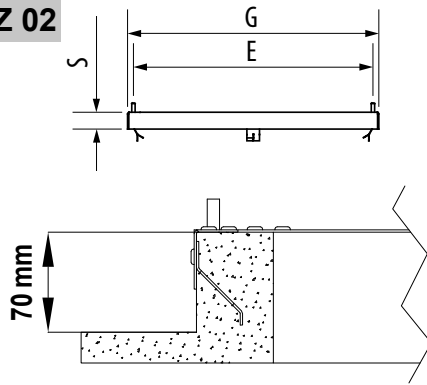
TCDZ 02**Sealing frame**

Embed the frame into the constructed support and make sure that the fixing lugs are embedded into the concrete.

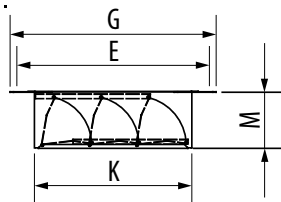
TCDZ 03**Energy-saving component**

Assemble the energy-saving component inside the upstands, under the casing. It is incompatible with the use of the TCDZ 05 adapter plates and the TCDZ 01 standard support. Make sure that the components are able to move freely before the casing is assembled. Provide for a drop in pressure of 50 Pa.

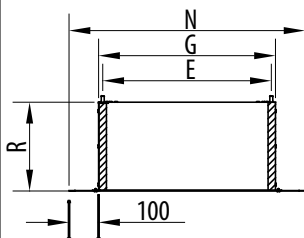
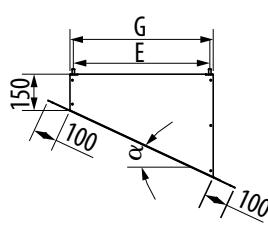
TCDZ 04**TCDZ 07****Straight, inclined and acoustic upstand**

According to DTU 43.1, it is possible to attach a TCDZ 03 energy-saving component or a TCDZ 05 (excluding TCDZ 09) adapter plate which is placed inside the upstand.

For any casing with an acoustic straight upstand (TCDZ 09), provide for a drop in pressure of 80 Pa.

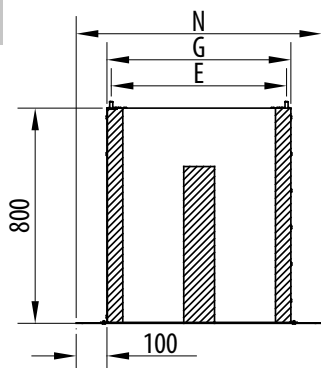
TCDZ 09**TCDZ 05****TCDZ 05: Adapter plate**

The adapter plate makes it possible to connect the casing to a circular duct. This part allows the aeraulic connection and it is not intended to bear the weight of the casing. It is incompatible with the use of the TCDZ 03 energy-saving component and the TCDZ 09 acoustic upstand.

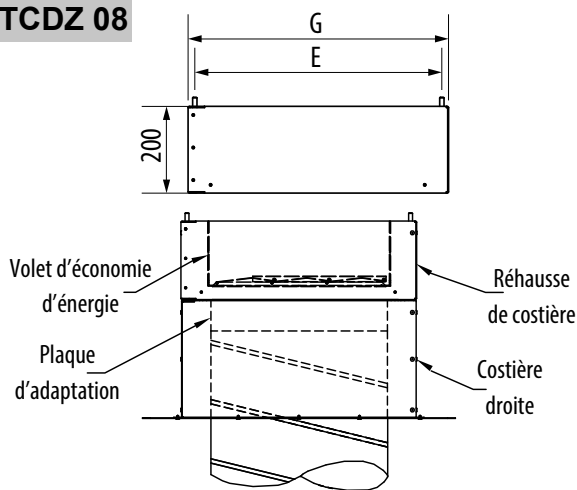
TCDZ 08**200 mm upstand lift**

Makes it possible to increase the height of the casing by 200 mm, to insert a TCDZ 05 adapter plate between the casing and the TCDZ 03 energy-saving component or to mount a TCDZ 03 energy-saving component onto a TCDZ 02 sealing frame.

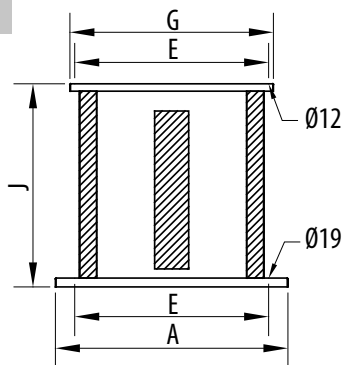
SILS**Sound absorber**

Provide for a drop in pressure of 80 Pa.

DRAIN (KITCHEN OPTION)

To install the drain at the bottom of the casing, make a 22 mm hole, position the drain with its seal and attach it with 2 3.5 x 19 screws (recommendation, screws not supplied).

Casing size	Accessory size	A	E	G	J	S
355/400	2	540	450	478	630	30
450/500	3	660	570	598	700	40
630	4	800	668	698	700	40
710	5	930	830	866	700	40

Casing size	Accessory size	M	N	K	R	Ø D	T
355/400	2	145	678	400	300/500/700	315/355/400/450*	50/65/80/80
450/500	3	170	798	490	300/500/700	400/450/500/560*	80/80/80/80
630	4	170	898	605	300/500/700	450/500/560/630	80/80/80/90
710	5	190	1066	730	300/500/700	560/630/710	80/90/120

* These adapter plates can only be mounted with the following accessories: TCDZ02, 04, 07 and 08

Accessory	TCDZ 02	TCDZ 03	TCDZ 05		SILS
	Size	Weight (Kg)	Weight (Kg)	ØD	Weight (Kg)
355/400	2,5	5,0	315/355/400/450*	1,8/1,5/1,2/0,8	23,0
450/500	4,0	6,0	400/450/500/560*	3,6/3,1/2,5/1,7	37,0
630	4,5	8,0	450/500/560/630	5,1/4,5/3,7/2,7	45,0
710	6,0	11,0	560/630/710	11,8/10,3/8,3	65,0

Accessoire	TCDZ 04		TCDZ 07 (30°)	TCDZ 09	TCDZ 08
	Size	R	Weight (Kg)	Weight (Kg)	Weight (Kg)
355/400	300/500/700		11,0/15,5/20,0	11,2	34,0
450/500	300/500/700		13,5/19,0/25,0	14,8	51,0
630	300/500/700		20,5/29,5/38,0	24,2	65,5
710	300/500/700		25,5/37,0/48,0	32,4	90,5

3.4 Handling

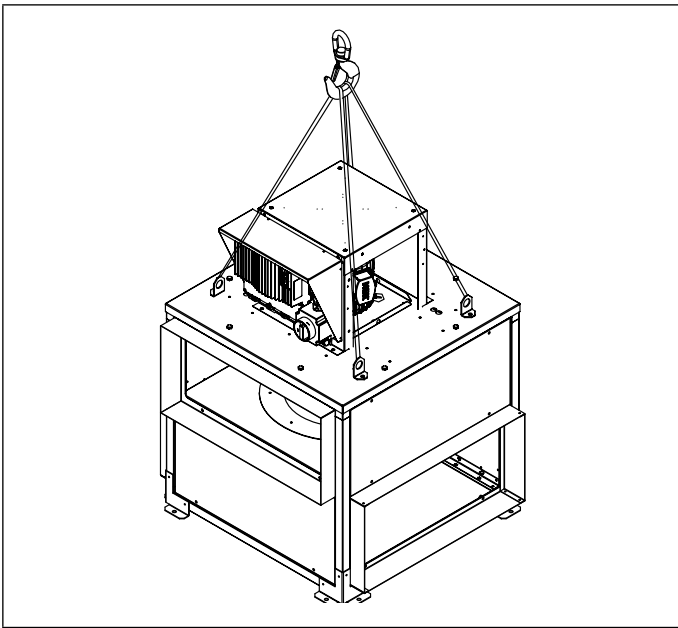

To keep people safe or prevent damage to property, use compliant handling equipment that is in a good condition.

The casing must be lifted at the 4 lifting lugs.

Use slings with a length that is at least double the height of the casing. Make sure that the slings do not rub against the motor cowl or the electrical accessories.

If in doubt, detach it to avoid any damage.

3.5 Casing assembly

The support surface that will support the base of the casing must be as flat as possible (sealing frame or upstand supplied on demand). A seal of foam or similar material (not supplied) is recommended between the support surface and the base of the casing. A maximum incline of 2.5° is tolerated between the motor axis and the vertical axis (see diagram below).

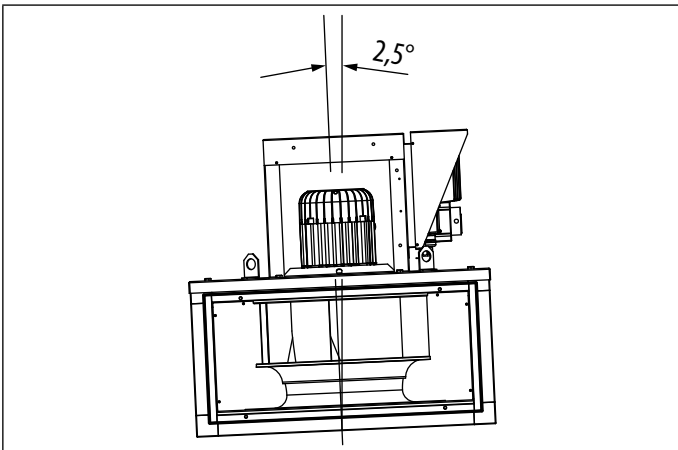

Make sure that the support is adapted to the weight of the whole machine and its various accessories. Attach the casing at the $\varnothing 20$ holes provided for this purpose. You are advised to use a LL washer. Any screws that are not properly tightened may make noises and cause harmful vibrations. Once the machine has been correctly set up, make sure that the motor turbine is able to rotate freely without any friction or noise. Vibration isolating devices are available: KUBZ 05.

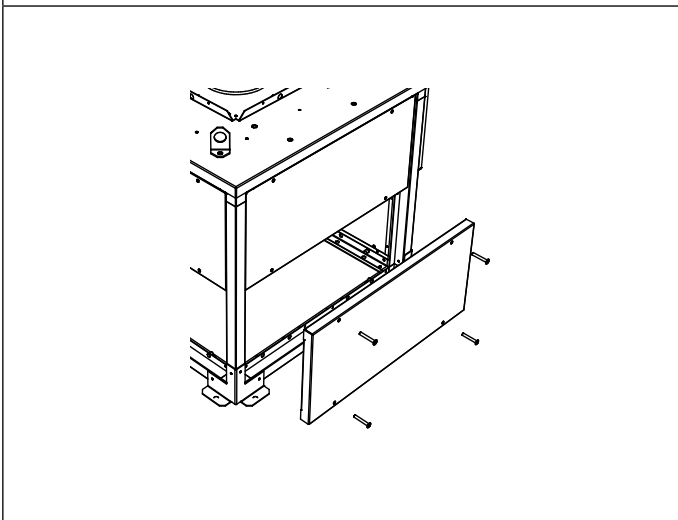

Detaching and re-assembling casing panels

The smooth side panels are easy to detach by loosening their screws. They are repositioned in the same way.

4. ELECTRICAL CONNECTION

4.1 Preliminary precautions

Electrical connections must be set up by qualified staff. Electrical connections will be set up in accordance with the Standard NF C15-100 which indicates that the motor must be protected by an all-pole mechanism whose opening clearance is 3 mm per contact. Do not forget the earthing connection.

In the event of use in smoke extraction, please refer to Standard NF S 61-932 for connection and installation. Use high-temperature cables of the CR1-C1 kind. The cable must be protected against UV radiation. Please note that cables and electrical accessories must be dimensioned according to Article 433-3 of Standard NF C 15-100: "the section of the conductors of the line is determined by a permissible current equal to 1.5 times the rated current of the motor". No thermal protection device is permitted on the smoke extraction circuit.

Furthermore, the cables must be protected against any mechanical stress when they are routed if the connection is established on the terminal box of the motor or on the proximity switch of the casing.

For the purpose of comfort, the motor must be protected by an adapted magnetothermal protection mechanism.

WARNING: use a voltage tester before you undertake any operation.

4.2 Caractéristiques électriques

Model	P. Nom (kW)	I. Nom. (A) 230V	I. Nom. (A) 400V	INTZ	Electrical protection necessary
355	0,70	3,05		INTZ 1V15	10 A
400	0,72	3,05		INTZ 1V15	10 A
450	1,24	5,40		INTZ 1V15	10 A
500	1,70		3,52	INTZ 1V15	16 A
630	3,16		6,99	INTZ 1V15	16 A
710	5,91		12,43	INTZ 1V22	16 A

4.3 Wiring of INTZ safety switch

Safety switch delivered factory wired and mounted.

Note: the safety switch is sized to be used in smoke extract application for a 400V three-phases or 230V single-phase 50/60Hz power supply.

Safety switch access

The switch is located next to the controller.

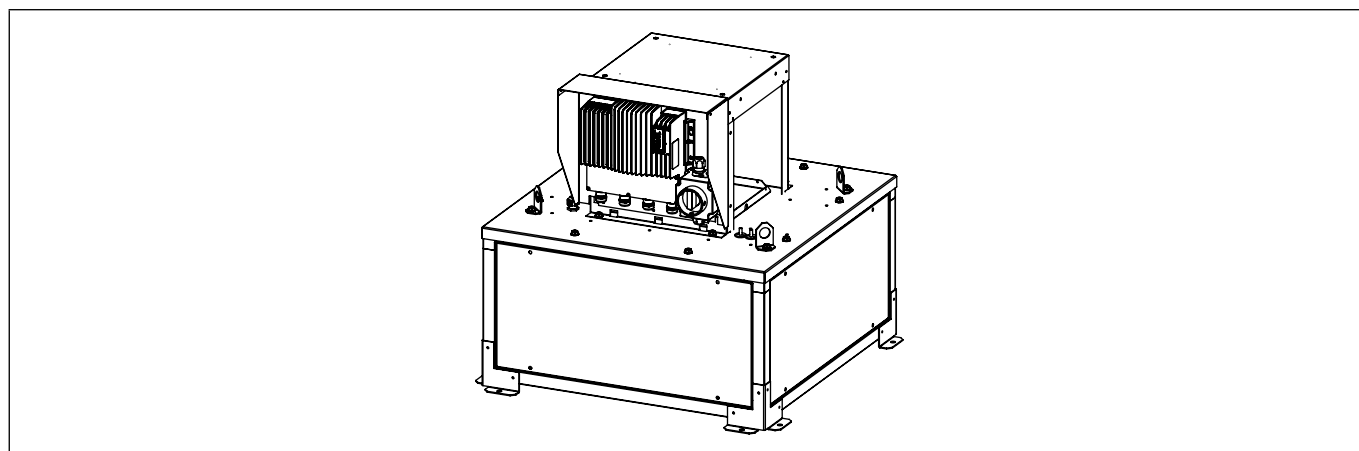

Wiring of version with INTZ safety switch 1V15

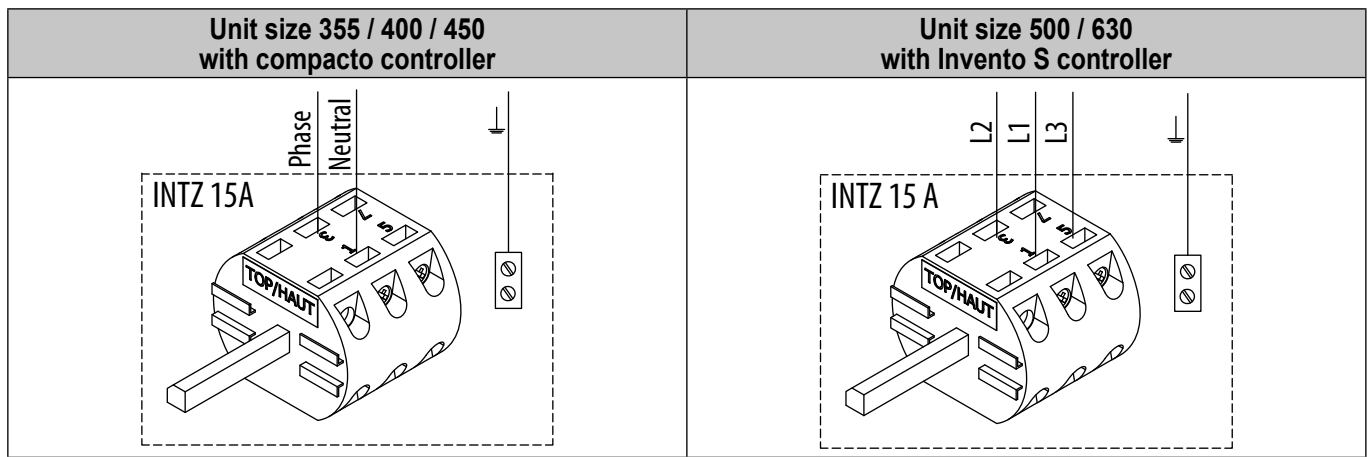

Wiring of version with INTZ safety switch 1V22

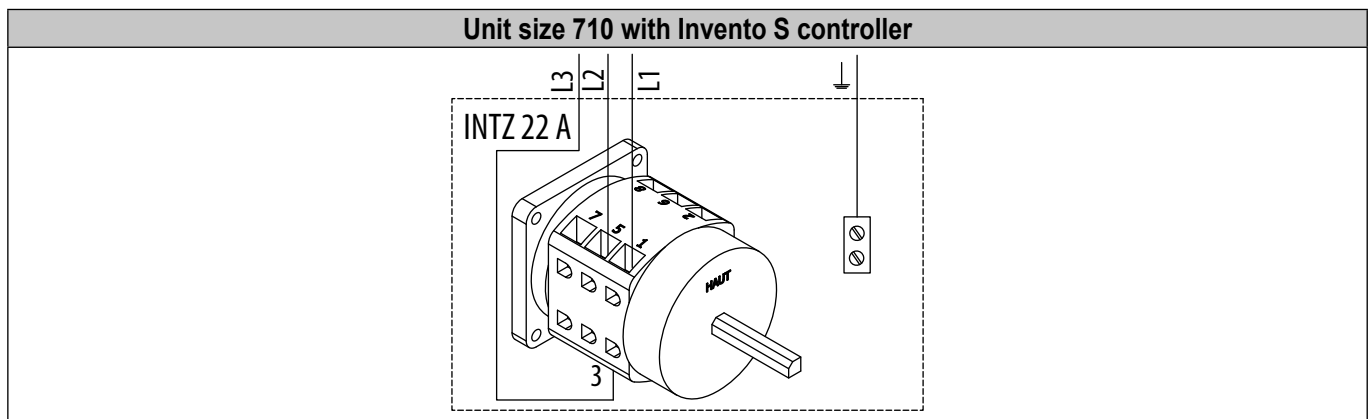

5. COMMISSIONING AND SETTING

5.1 Preliminary precautions

Before starting fan, make sure that the electric motor and impeller assembly rotate freely and that there is no object likely to be ejected by the turbine. The protection housings must be fastened to roof fan to prevent any accidental contact with rotating parts.

The machine should be attached to its support before power is applied.

Switch on just an instant to check the turbine's rotating direction.

WARNING: The impeller rotating direction must correspond to each speed in the direction indicated by the arrow on the product. A centrifugal backward fan unit with an impeller that does not rotate in the right direction still creates a flowrate and a low pressure in the duct. An incorrect rotating direction can lead to an abnormal overheating of the motor, resulting in its destruction and cancelling our manufacturer's warranty.

If the rotating direction is incorrect, cut off the electrical power supply, make sure no power is present, Contact after-sales service. Do not modify wirings, as this might seriously damages the unit.

While running, make sure that the motor's absorbed current is not more than 10% above the name plate indicated current .

Once the roof fan is installed and the tests successfully completed, present the main points of the operation and maintenance manual to the user, and explain:

- How to start up and shut down.
- How to change the operating modes.

Then hand over to the user the technical manual of the roof fan and the mounted accessories so that he can keep it handy to consult it at any time.

5.2 Controllers

The ECM motor controller controls this motor according to an adjusting potentiometer on the controller, an external 0-10V signal or a set point given by Modbus BMS .
The Modbus BMS connection, present as standard, allows you to adjust the flow rate set point or pressure, and to read the controller registers to find out the state of the roof fan.

5.2.1 Controller terminal block

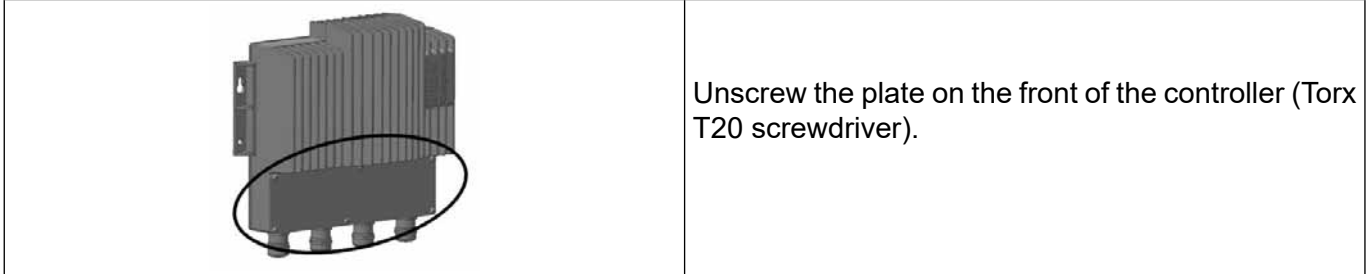

5.2.2 Adjustment potentiometer

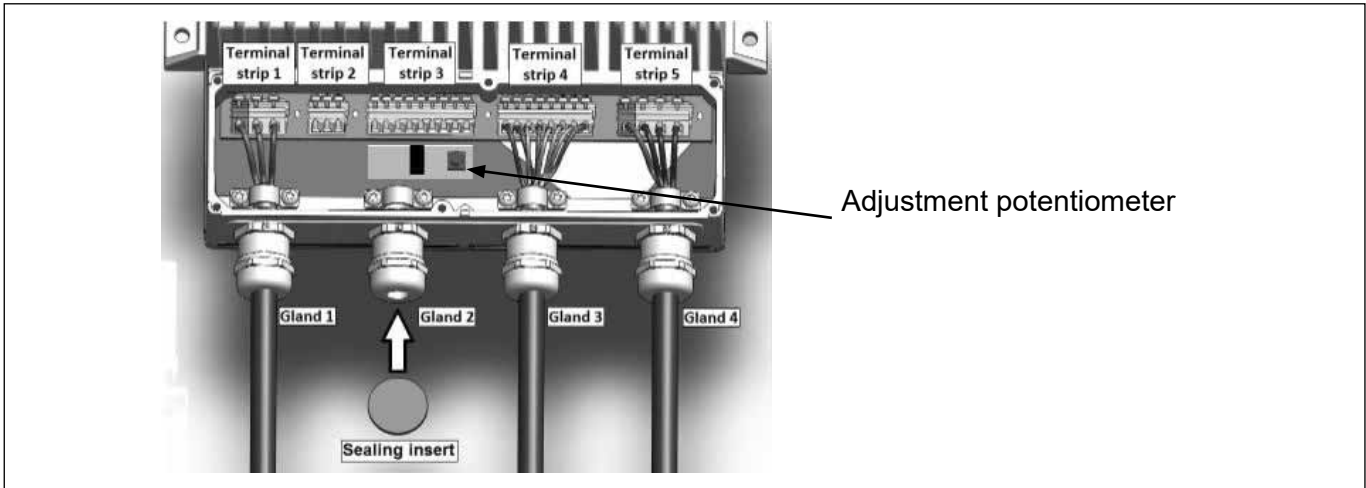

5.2.3 Fault correction

In the event of a fault, restarting operation after switching off the power for 5 minutes may allow the controller to reset. A fault relay allows us to identify the main causes of faults on the controller.

Connection of the relay:

For sizes 355/400/450: Controller - Terminals 4, 5, 6.

For sizes 500/630/710: Controller - Terminals 17, 18, 19.

Regardless of the principle of operation of the roof fan, the relay operates in the following manner:

STATE OF THE UNIT	State of the relay**	Compacto	Invento
"Normal" operation (COP, CAV, VAV)	NO	5-6	18-19
Supply cut off	NC	4-5	17-18
On / Off switch open - the wheel is stationary but power is on to the controller.	NC	4-5	17-18
Loss of phases* - possibility that during a loss of phase the wheel continues to turn.	NC	4-5	17-18

*If the control unit detects a fault more than once, notably a phase problem twice, the roof fan will not restart automatically. (**)

NO.: normally open, NC: normally closed.

Switch off the power supply for 5 min and restart the roof fan. If the problem persists, it is possible to identify the nature of the problem in the registers of the Modbus. The controller operating manual is available for more information on www.vim.fr.

For sizes 355/400/450

The "Inputs" table allows you to read the following information:

Register	Fault	Value	Description
0	Power on	0-1	1 = Voltage too low to operate
1	Over voltage	0-1	1 = Voltage too high to operate
2	IGBT over current	0-1	1 = Over current protection triggered
3	Temperature	0-1	1 = Thermal protection triggered, power reduced
4	Phase loss	0-1	1 = loss of phase or motor synchronism
5	PFC over current	0-1	1 = PFC protection (Power Factor Correction) FET triggered
6	CRC settings	0-1	1 = Monitoring of parameters has failed (TBD)
7	Circuit fault	0-1	1 = Error detected during checking of the internal circuits.
8	Motor fault	0-1	1 = Abnormal motor behaviour
9	On temperature	0-1	1 = Converter too hot to operate
10	I2R IGBT fault	0-1	1 = IGBT programme protection triggered
14	Restart fault	0-1	1 = Fault condition repeated more than once in a short time. The power converter must be restarted or reset.
15	Fire mode	0-1	1 = Fire mode enabled
16	Operation Active	0-1	1 = Operation Active
17	Relay Active	0-1	1 = relay output enabled
18	Awaiting shut-down	0-1	1 = The engine should stop, but is still running.
24	Speed regulation	0-1	Speed regulator enabled
25	Power regulation	0-1	Power limit regulator enabled
26	Current regulation	0-1	Line current regulator enabled
27	Over modulation regulation	0-1	Over modulation reached. The converter can no longer provide the voltage required for the motor.
28	Regeneration regulation	0-1	Motor in regeneration. Increased speed to prevent over voltage at the DC connection.
29	Phase current regulation	0-1	Motor phase RMS current limit
30	Synchronisation regulation	0-1	Motor still in synchronous mode

For sizes 500/630/710

The "Inputs" table allows you to read the following information:

Register	Fault	Value	Description
0	Power on	0-1	1 = Voltage too low to operate
1	Over voltage	0-1	1 = Voltage too high to operate
2	SW over current	0-1	1 = current protection of the IGBT software
3	On temperature	0-1	1 = Converter too hot to operate
4	Phase loss	0-1	1 = Loss of phase or of main supply
5	Earth current fault	0-1	1 = asymmetrical load (sum of all currents >3 A)
6	CRC settings	0-1	1 = Monitoring of parameters has failed (TBD)
7	Driver fault	0-1	1 = Transistor driver initialization fault
8	ADC fault	0-1	1 = ADC conversion error
9	SPI communication fault	0-1	1 = No communication between the processors
10	Reduction in power	0-1	1 = Reduction in the power of the controller.
11	Stoppage of the reduction in power	0-1	1 = Stop (motor stop) temperature of the controller reached
12	HW over current	0-1	1 = IGBT software current protection
13	FLW enabled	0-1	1 = Weakening of the active field
14	System error	0-1	1= Machine error

Refer to the controller operating manual if necessary (available on www.vim.fr).

5.2.4 Modbus connection - Connection to a BMS

In the case of a connection to a BMS, the Modbus connection, present in standard, allows:

- KUBAIR® F400 ECOWATT® Single phase or 3-phase - Control of the VAV variable flow rate:
 - On / Off
 - Speed adjustment
 - reading of registers (state of the casing).
- KUBAIR® F400 ECOWATT® Single phase or 3-phase - Adjustment to CAV constant flow rate:
 - On / Off
 - adjustment of the flow rate set point,
 - reading of registers (state of the casing).
- KUBAIR® F400 ECOWATT® Single or 3-phase - Adjustment to COP constant pressure:
 - On / Off
 - adjustment of the pressure set point,
- reading of registers (state of the casing).

Refer to the corresponding paragraph below for the connection and the setting of your casing.

5.2.5 Default configuration settings

A USB converter with RS 485 is necessary for you to connect to the registers via a PC, as well as an interface of the same type as ModBus Doctor.

	Single-phase model*	3-phase model*
MODBUS address	1	80
Baud rate		19200
START Bit		1
STOP Bit		1
Parity		NONE

* For additional information refer to the roof fan controller manual (available on www.vim.fr).

5.2.6 Input register table

The "Input Register" table allows you to read the following information:

Register	Fonction	Resolution	Description
Single-phase model			
4	Speed	1	rpm
8	Power	0,1	W
9	An1 input	0,01	V
10	An2 input	0,01	V
11	Pot input	0,01	V
3-phase model			
0	Speed	1	rpm
2	Power	1	W
9	An1 input	0,01	V
10	An2 input	0,01	V

For all other information on the setting of Modbus, contact the After-Sales service department.

5.3 Operation for smoke extraction

The KUBAIR® F400 ECOWATT® is approved for extraction of hot gases and smoke in the event of a fire. This mode of operation is automatic and does not require any setting: In the case of extraction of gas at a temperature > 200°C, the roof fan will automatically switch to high speed with its internal thermal protections inhibited.

The smoke extraction mode must be triggered manually with a BDRA type control unit.

The CAV/VAV/COP modes are no longer accepted.

5.4 Ventilation fault indication

Replaces the use of a BDEZ type pressure switch

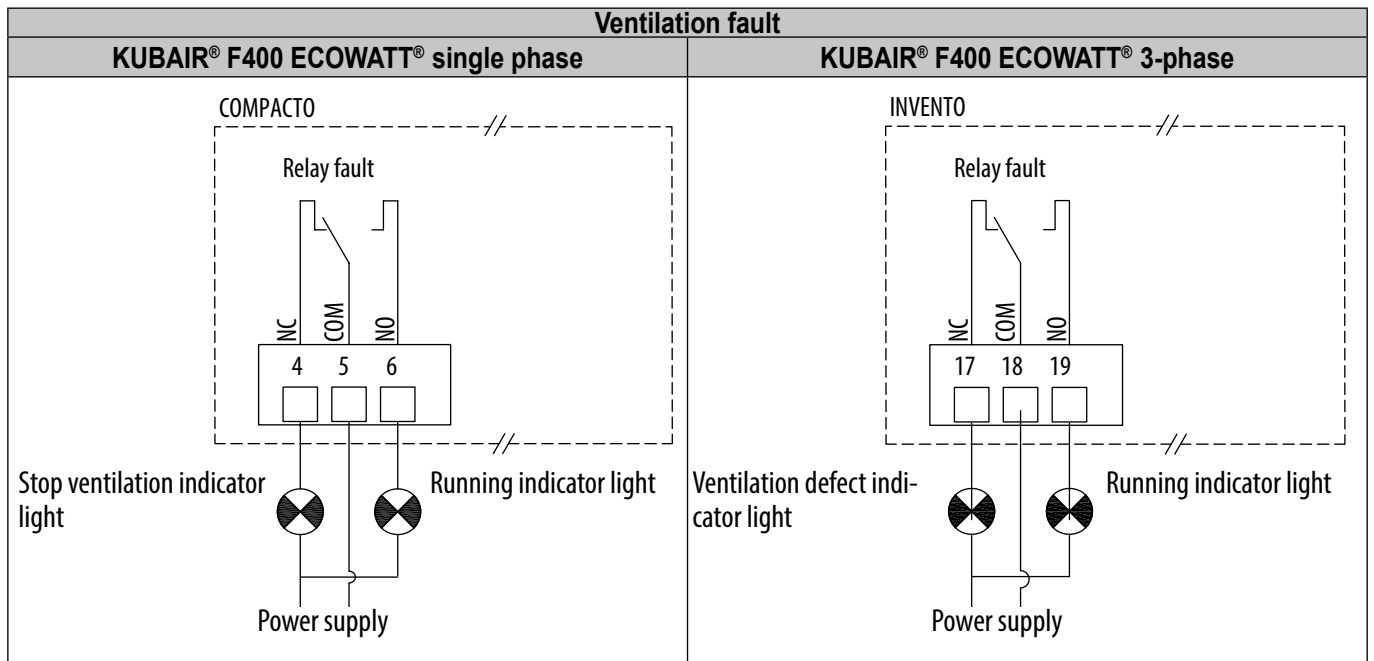

5.5 KUBAIR® F400 ECOWATT® Single-phase - VAV variable flow rate control

VAV - Slaving to an external signal

In variable speed operation, the controller pilots the speed of the roof fan linearly. The controller will vary the speed of the roof fan between 200 rpm (min. speed), and its maximum speed in proportion to the signal sent by the external sensor. If the display is present on the roof fan, it will show you the flow rate in m³/h.

The speed adjustment can be done in different ways:

- by the potentiometer integrated in the controller,
- by a CVF ON/OFF + variation remote control,
- by an external 0-10V output,
- by a BCCA switch (0/LS/HS with adjustable LS),
- by a VRPZ voltage variator (allowing operation 0 / LS / HS with adjustable LS and HS),
- by flow rate control by Modbus BMS.

VAV - Regulation according to the deviation between the set point / external measurement

During operation at variable speed, the controller regulates the speed of the roof fan according to the set point-measurement deviation. The set point is adjusted with the potentiometer built into the controller or a CVF type external control. If the display is present on the roof fan, it will show you the flow rate in m³/h.

Example of slaving and VAV regulation according to measurement of the outside temperature:

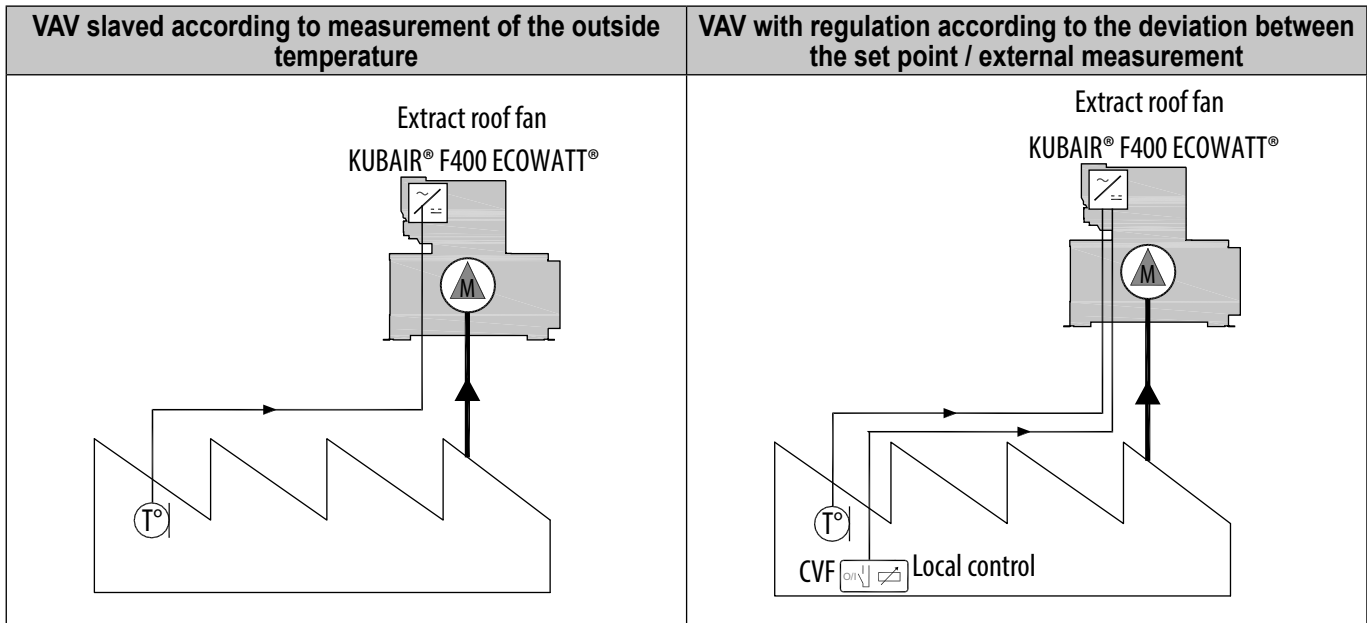

5.5.1 Connection

VAV type factory assembly and wiring, with or without display. **Connection of the power supply to the INTZ switch to be done by the customer.**

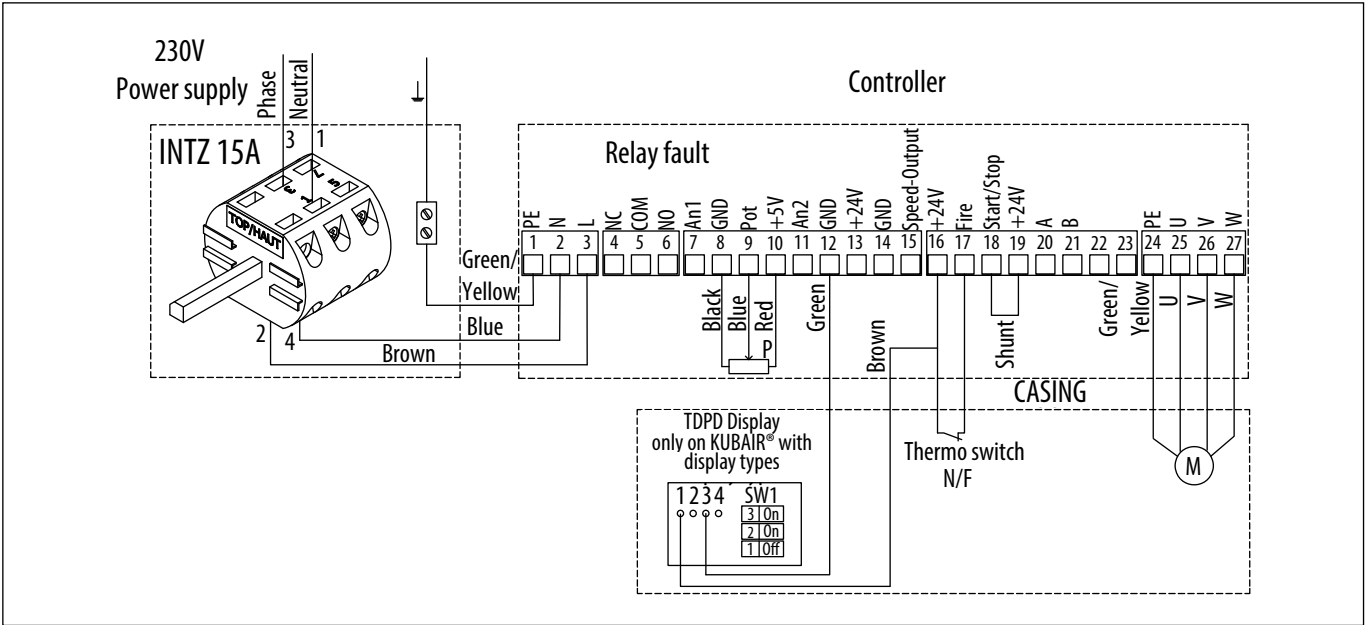

Wiring for accessories not supplied

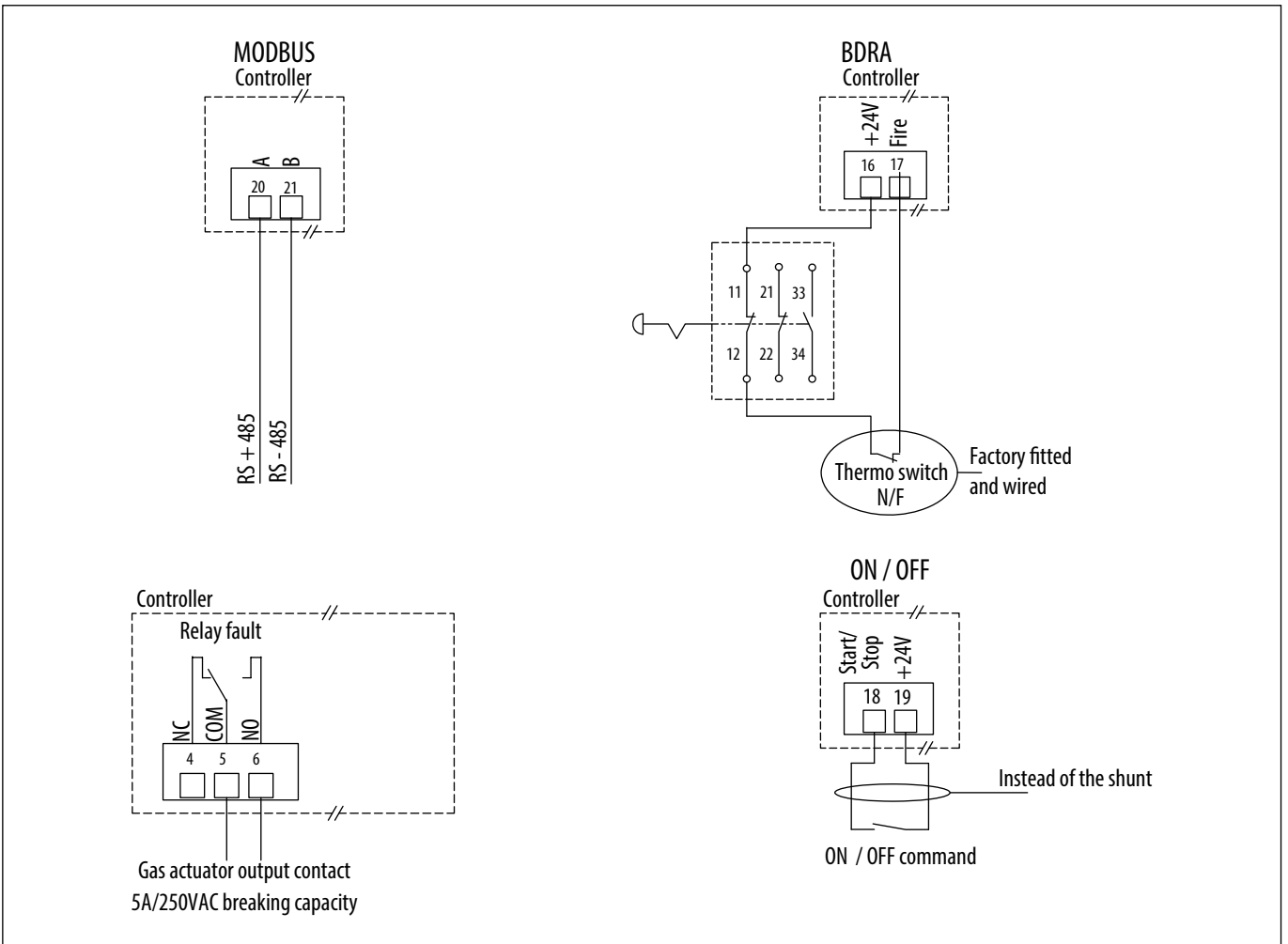

Wiring for manual adjustment and slaving to an external signal

When the speed adjustment is done by the CVF type remote control, the 0-10V output or the Modbus BMS, the factory-fitted potentiometer in the controller must be disconnected.

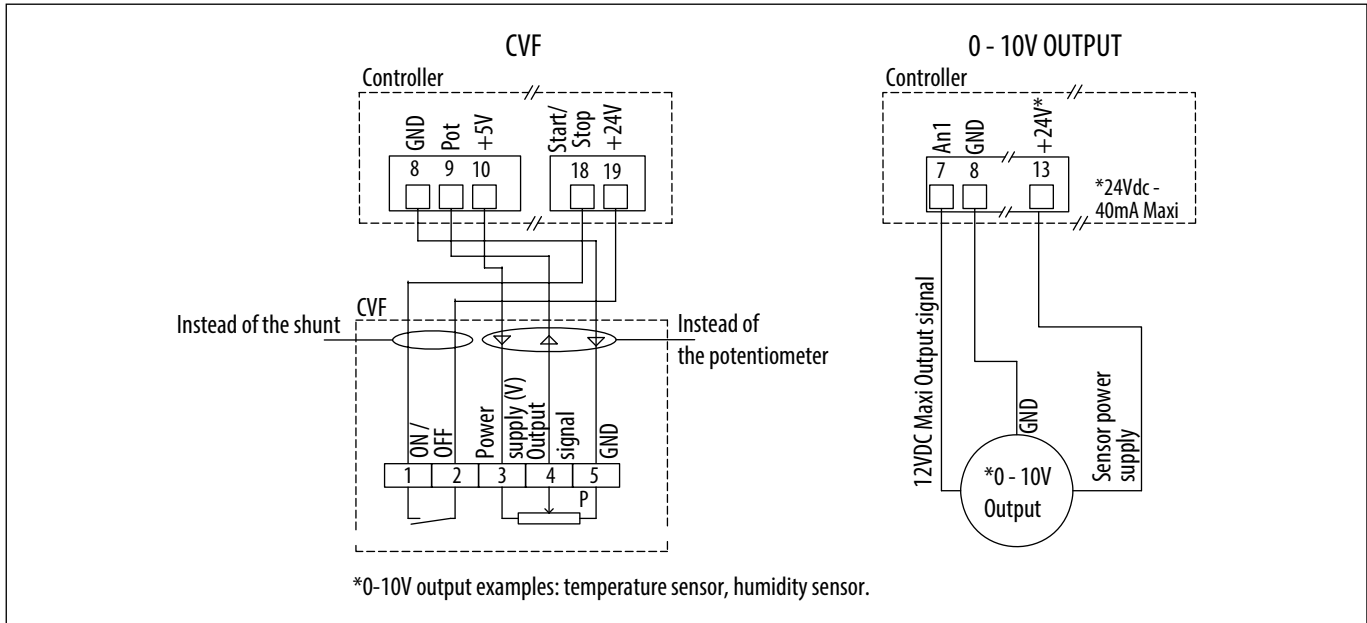

Wiring for manual two-speed control

0-LS-HS installation diagram, with adjustable LS

The LS is defined by the potentiometer of the controller, and the HS is the speed of the roof fan on a control signal of 10V. Choice of 0-LS-HS with a BCCA type 2S switch (accessory not supplied).

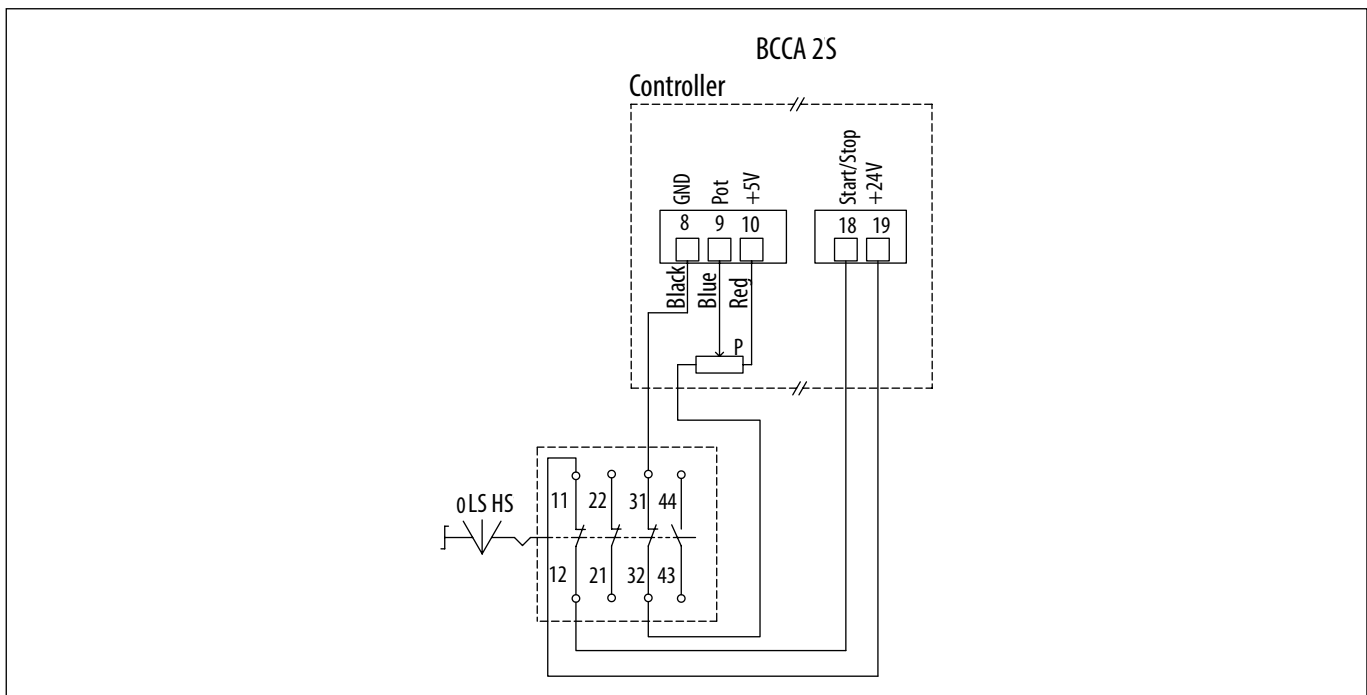

0-LS-HS installation diagram, with adjustable LS and HS

The PV and the GV are adjusted by a VRPZ voltage variator (accessory not supplied). 0-LS-HS choice with the VRPZ.

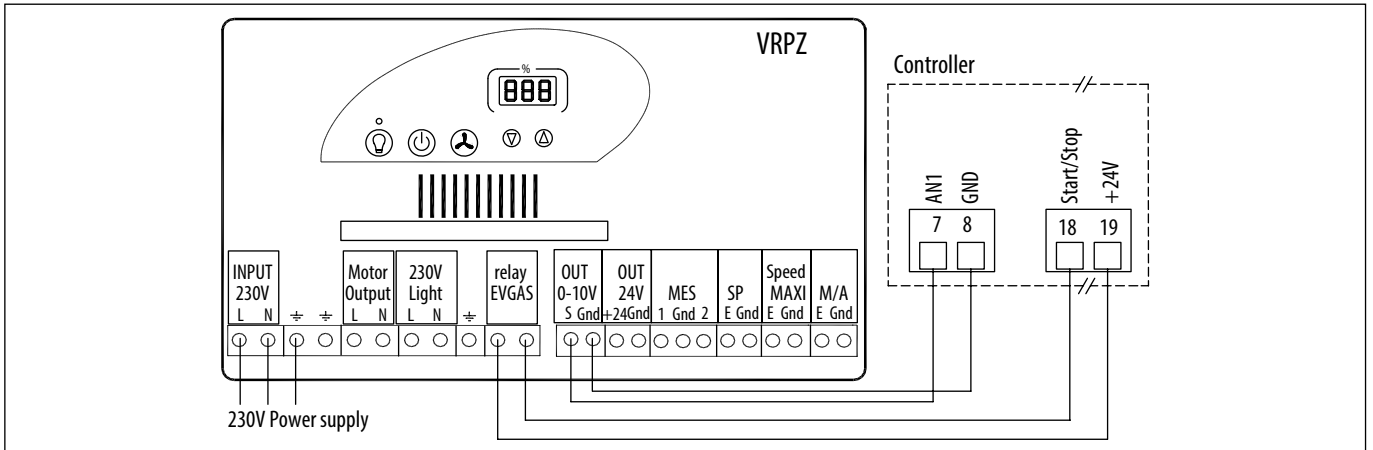

Wiring for regulation according to the deviation between the set point / external measurement

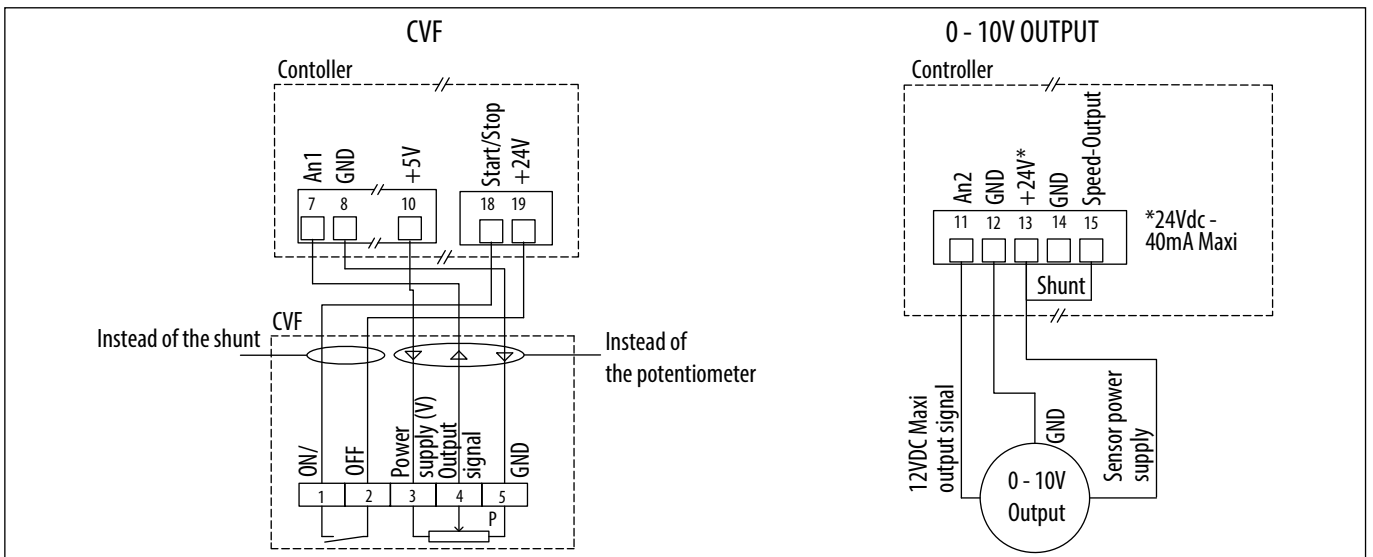

5.5.2 Speed adjustment (unregulated VAV)

By potentiometer, or CVF type remote control.

By default the roof fan is set to its maximum speed, in bold in the table below.

The potentiometer in the controller allows you to change the speed of the turbine to adjust the flow rate. The adjustment can be done with a CVF type remote control.

Correspondence table between the graduation of the internal potentiometer, the voltage applied on terminal 9 and the speed.

Graduation potentiometer	Voltage (V) at terminal 9	KUBAIR® F400 ECOWATT® 355	KUBAIR® F400 ECOWATT® 400/450
0	0	200 rpm	200 rpm
2	1	530 rpm	460 rpm
4	2	850 rpm	720 rpm
6	3	1 180 rpm	980 rpm
8	4	1 500 rpm	1 240 rpm
10	5	1 830 rpm	1 500 rpm

For information: The flow rate is proportional to the speed of rotation.

$$Q_{v2} = Q_{v1} \times \left(\frac{N_2}{N_1} \right) \quad N \text{ is the speed of rotation.}$$

By 0-10V output

Correspondence table between the voltage applied on terminal 7 and the speed.

Voltage (V) at terminal 7	KUBAIR® F400 ECOWATT® 355	KUBAIR® F400 ECOWATT® 400/450
0	200 rpm	200 rpm
2	530 rpm	460 rpm
4	850 rpm	720 rpm
6	1 180 rpm	980 rpm
8	1 500 rpm	1 240 rpm
10	1 830 rpm	1 500 rpm

Speed adjustment 0 / LS / HS (adjustable LS)

The adjustment can be done by a BCCA type 2S 0 / LS / HS switch.

The low speed is adjusted with the controller potentiometer.

The high speed is the roof fan speed with a control signal of 10V.

Speed adjustment 0 / LS / HS (adjustable LS and HS)

The adjustment can be done with a VRPZ voltage variator.

The low speed and the high speed are adjusted with the VRPZ, see VRPZ operating instructions.

Speed adjustment by the Modbus BMS

The adjustment can be done with a Modbus BMS . To know the parameters of the Modbus connection, refer to § "5.2.4 Modbus connection - Connection to a BMS".

After you wired your Modbus Link:

Turn on the power to connect yourself to the controller. The roof fan wheel must be stopped.

Steps	Register numbers	Value to be entered
1 - Access to Level 1	5	1
2 - Change in the operating mode of the controller	6	2
3 - Saving of changes	5	10000
4 - Changing the set point	0	Between 1000 and 10,000 to set the desired speed of the roof fan, see the table below
Fan stop	0	0

Register set point 0	KUBAIR® F400 ECOWATT® 355	KUBAIR® F400 ECOWATT® 400/450
1000	200 rpm	200 rpm
2000	380 rpm	345 rpm
3000	560 rpm	490 rpm
4000	740 rpm	630 rpm
5000	920 rpm	780 rpm
6000	1 110 rpm	920 rpm
7000	1 290 rpm	1 070 rpm
8000	1 470 rpm	1 210 rpm
9000	1 650 rpm	1 360 rpm
10000	1 830 rpm	1 500 rpm

5.6 KUBAIR® F400 ECOWATT® Single-phase - CAV constant flow rate control

During operation at constant flow rate, the controller regulates the speed of the roof fan to obtain the set point flow rate. A display installed under the cap indicates the flow rate measured in m³/h. The flow rate set point can be adjusted by the potentiometer in the controller, by a CVF ON/OFF + variation remote control, by an external 0-10V output or by Modbus BMS.

5.6.1 Wiring

CAV type factory assembly and wiring. **Connection of the power supply to the INTZ switch to be done by the customer.**

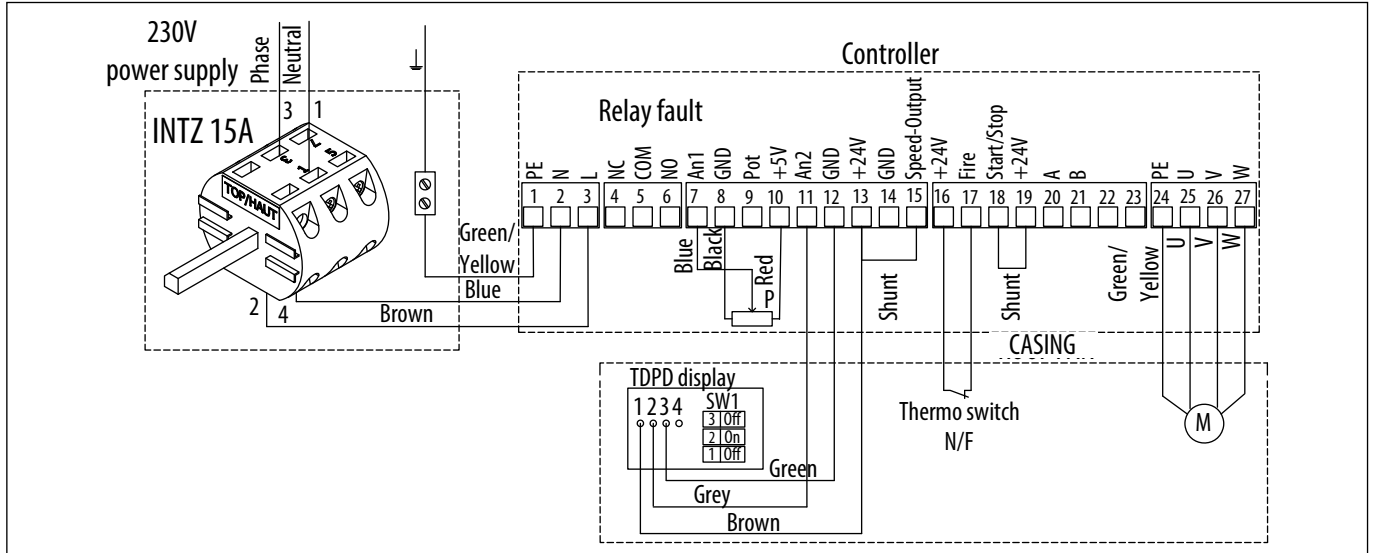

Wiring for accessories not supplied

When the flow rate set point adjustment is given by the CVF type remote control or the 0-10V output, the factory-fitted potentiometer in the controller must be disconnected.

When the speed set point setting is given by the MODBUS BMS the factory-fitted potentiometer in the controller must be disconnected, **as well as the shunt between terminals 13 and 15.**

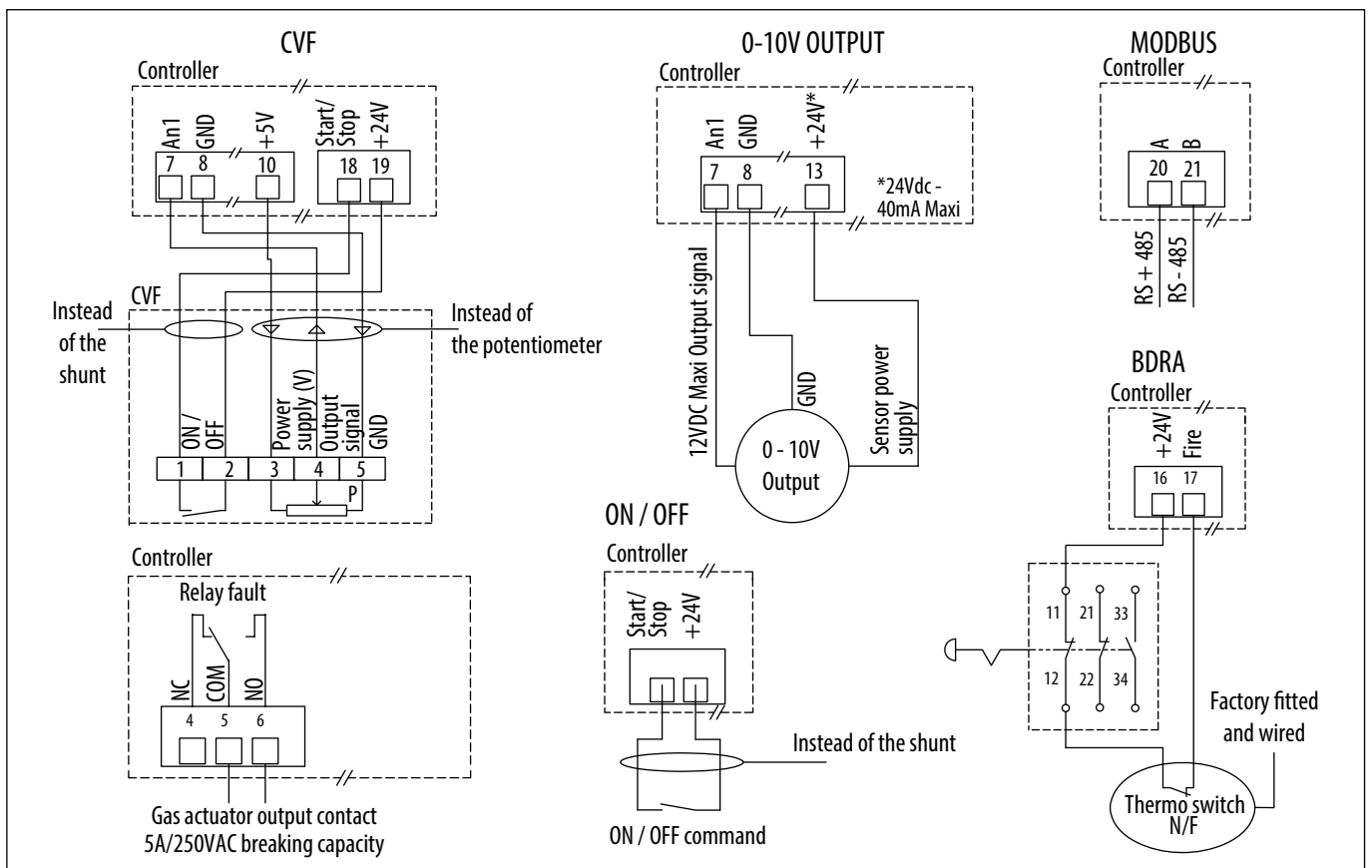

5.6.2 Adjusting the flow rate set point,

By potentiometer, CVF type remote control or 0-10V output.

Adjustment of the flow rate set point by potentiometer, CVF type remote control or 0-10V output.

The potentiometer in the controller allows you to change the flow rate set point.

The display under the cap shows the calculated flow rate.

For Sizes 355 / 400 / 450 : the display shows m³/h.

Graduation potentiometer	Flow rate (m ³ /h)			Graduation potentiometer	Flow rate (m ³ /h)		
	355	400	450		355	400	450
0	0	0	0	6	N/A	N/A	8170
1	2040	3050	3340	7	N/A	N/A	N/A
2	2880	4320	4720	8	N/A	N/A	N/A
3	3530	5290	5780	9	N/A	N/A	N/A
4	4080	6100	6680	10	N/A	N/A	N/A
5	N/A	N/A	7460				

N/A : max. flow rate already reached

Note: After each adjustment wait 1 minute for the fan speed to stabilize.

By Modbus BMS

The flow rate set point can be given by a Modbus BMS set point. To find the settings of the Modbus connection, refer to § "5.2.4 Modbus connection - Connection to a BMS".

After you wired your Modbus link:

Turn on the power to connect yourself to the controller. The roof fan wheel must be stopped.

Steps	Register numbers	Value to be entered
1 - Access to Level 1	5	1
2 - Change in the operating mode of the controller	6	9
3 - Saving of changes	5	10000
4 - Changing the set point	16	Between 0 and 1,000 to define the desired flow rate set point, see the table below

Register set point 16	KUBAIR® F400 ECOWATT® 355	KUBAIR® F400 ECOWATT® 400	KUBAIR® F400 ECOWATT® 450
100	2 040 m ³ /h	3 050 m ³ /h	3 340 m ³ /h
200	2 880 m ³ /h	4 320 m ³ /h	4 720 m ³ /h
300	3 530 m ³ /h	5 290 m ³ /h	5 780 m ³ /h
400	4 080 m ³ /h	6 100 m ³ /h	6 680 m ³ /h
500	N/A	N/A	7 460 m ³ /h
600	N/A	N/A	8 170 m ³ /h
700	N/A	N/A	N/A
800	N/A	N/A	N/A
900	N/A	N/A	N/A
1000	N/A	N/A	N/A

For information: Calculation of the flow rate according to the set point

$$Q_v = K \times 2,5 \times \text{set point}$$

Size of KUBAIR® F400 ECOWATT®	Coeff. K
355	129
400	193
450	211

5.7 KUBAIR® F400 ECOWATT® Single-phase - COP constant pressure control

During operation at constant pressure, the controller regulates the speed of the roof fan to obtain the set pressure. If the display is present on the roof fan, it will show you the pressure in Pa. The pressure set point can be adjusted by the potentiometer in the controller, by a CVF ON/OFF + variation remote control, by an external 0-10V output or by Modbus BMS.

5.7.1 Wiring

COP type factory assembly and wiring. **Connection of the power supply to the INTZ switch to be done by the customer.**

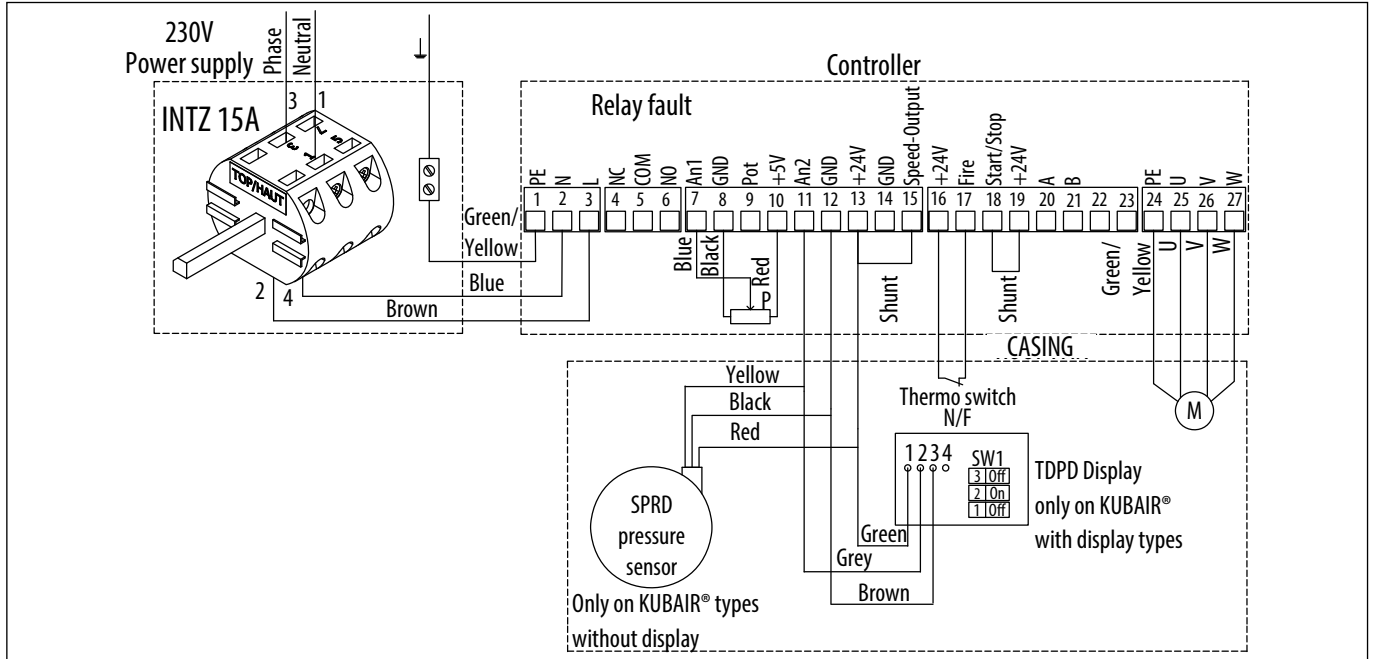

Wiring for accessories not supplied

When the pressure set point is given by the CVF type remote control or the 0-10V output, the factory-fitted potentiometer in the controller must be disconnected.

When the speed set point is given by the MODBUS BMS the factory-fitted potentiometer in the controller must be disconnected, **as well as the shunt between terminals 13 and 15.**

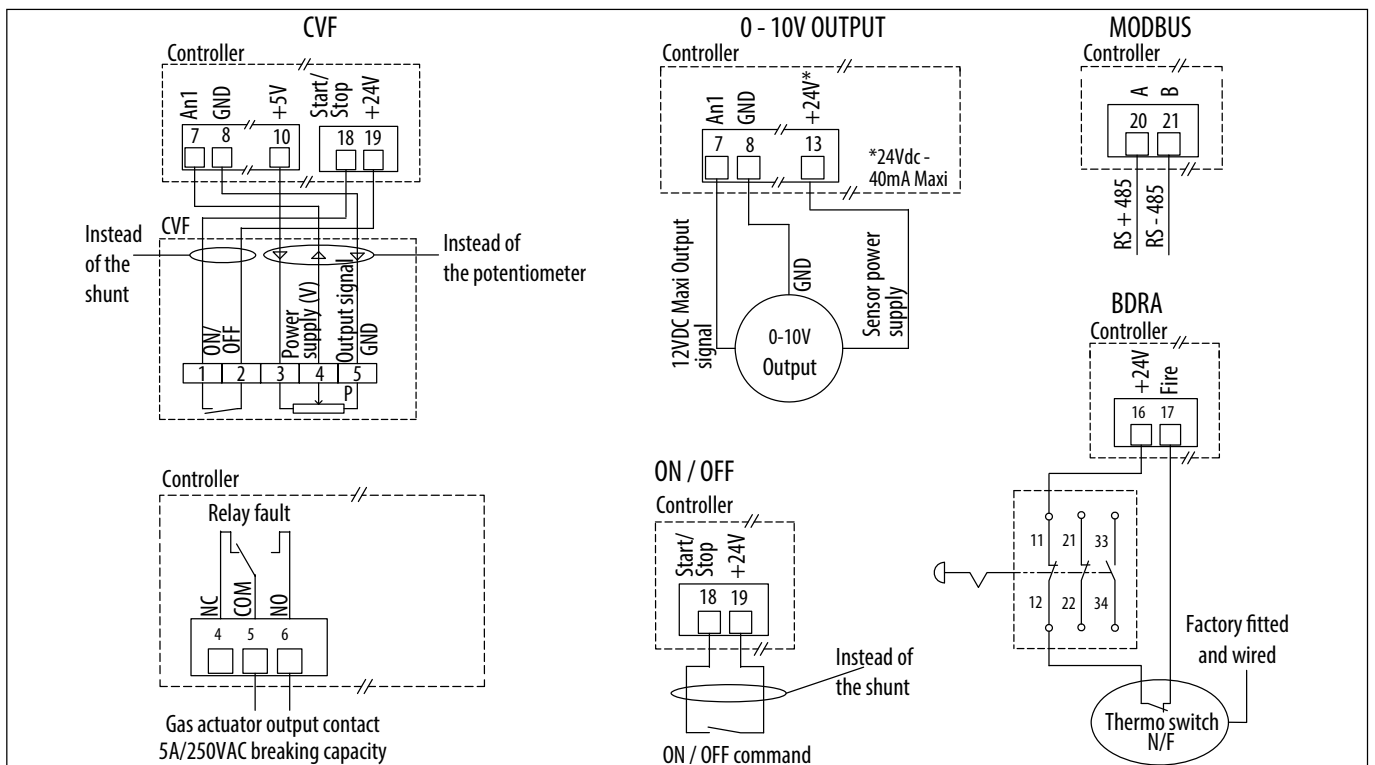

5.7.2 Adjusting the pressure set point

By potentiometer, CVF type remote control or 0-10V output.

By default the roof fan is set to obtain the pressure in bold in the table.

The potentiometer in the controller allows you to change the pressure set point.

The set point can be given by a CVF type remote control or a 0-10V output.

Correspondence table between the potentiometer graduation, the voltage applied on terminal 7 and the pressure set point.

Note: After each adjustment wait 1 minute for the fan speed to stabilize.

Potentiometer graduation	Voltage (in V) at terminal 7	Without display	Voltage (in V) at terminal 7	With display*
0	0	0 Pa	0	0 Pa
1	0,5	0 Pa	0,5	80 Pa
2	1	100 Pa	1	160 Pa
3	1,5	200 Pa	1,5	240 Pa
4	2	300 Pa	2	320 Pa
5	2,5	400 Pa	2,5	400 Pa
6	3	500 Pa	3	480 Pa
7	3,5	600 Pa	3,5	560 Pa
8	4	700 Pa	4	640 Pa
9	4,5	800 Pa	4,5	720 Pa
10	5**	800 Pa	5**	800 Pa

*If the roof fan has a display, the display will show you the pressure measured at the roof fan plate (see diagram below).

**If 0-10V source, 5 to 10V: 800Pa.

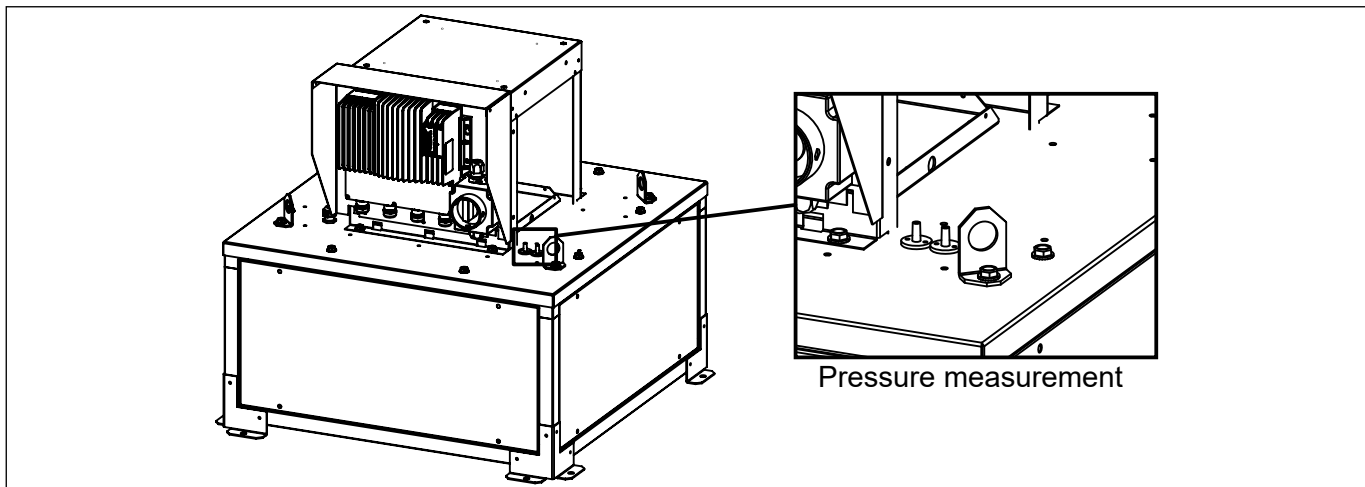

By Modbus BMS

The pressure set point can be given by a Modbus BMS set point. To find the Modbus connection settings, refer to § "5.2.4 Modbus connection - Connection to a BMS".

After you have wired your Modbus link:

Turn on the power to connect yourself to the controller. The roof fan wheel must be stopped.

Modbus register table:

Steps	Register numbers	Value to be entered
1 - Access to Level 1	5	1
2 - Change in the operating mode of the controller	6	9
3 - Saving of changes	5	10000
4 - Changing the set point	16	Between 0 and 1000 to define the desired pressure set point, see the table below

Without display	
Register set point 16	Pressure (Pa)
100	100
200	300
300	500
400	700
450	800
450 à 1000	800

With display	
Register set point 16	Pressure (Pa)
100	160
200	320
300	480
400	640
500	800
600	960
700	1 120
800	1 280
900	1 440
1000	1 600

5.8 KUBAIR® F400 ECOWATT® 3-phases - VAV variable flow rate control

VAV - Slaving to an external signal

In variable speed operation, the controller pilots the speed of the roof fan linearly. The controller will vary the speed of the roof fan between 200 rpm (min. speed), and its maximum speed in proportion to the signal sent by the external sensor. If the display is present on the roof fan, it will show you the flow rate in m³/h.

The speed adjustment can be done in different ways:

- control by a potentiometer in the controller,
- control by a CVF ON/OFF + variation remote control,
- control by an external 0-10V output,
- 0 / LS / HS switch (adjustable LS): a 2S BCCA The low speed is adjusted with the controller potentiometer; the high speed is the roof fan speed with a control signal of 10V.
- by a VRPZ voltage variator (allowing 0 / LS / HS operation with adjustable LS and HS),
- flow rate control by Modbus BMS.

VAV - Regulation according to the deviation between the set point / external measurement

During operation at variable speed, the controller regulates the speed of the roof fan according to the set point-measurement deviation. The set point is adjusted with the potentiometer built into the controller or a CVF type external control. If the display is present on the roof fan, it will show you the flow rate in m³/h.

Example of slaving and VAV regulation according to measurement of the outside temperature:

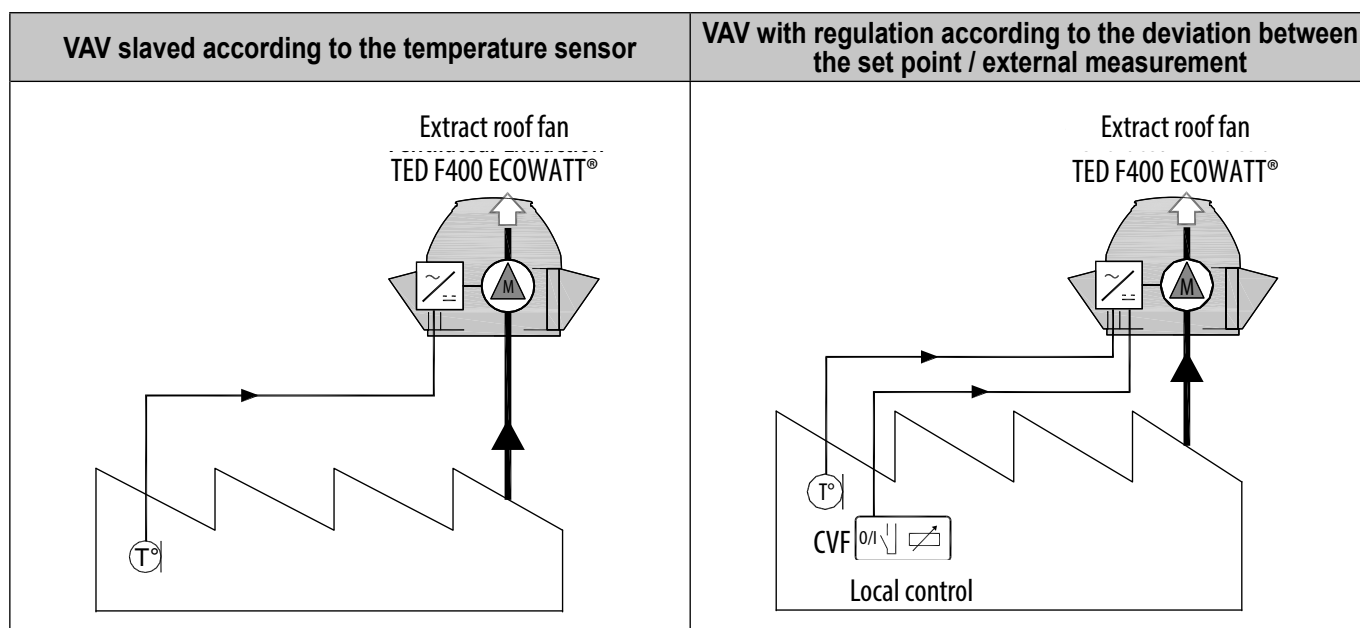

5.8.1 Wiring

VAV type factory assembly and wiring, with or without display. **Connection of the power supply to the INTZ switch to be done by the customer.**

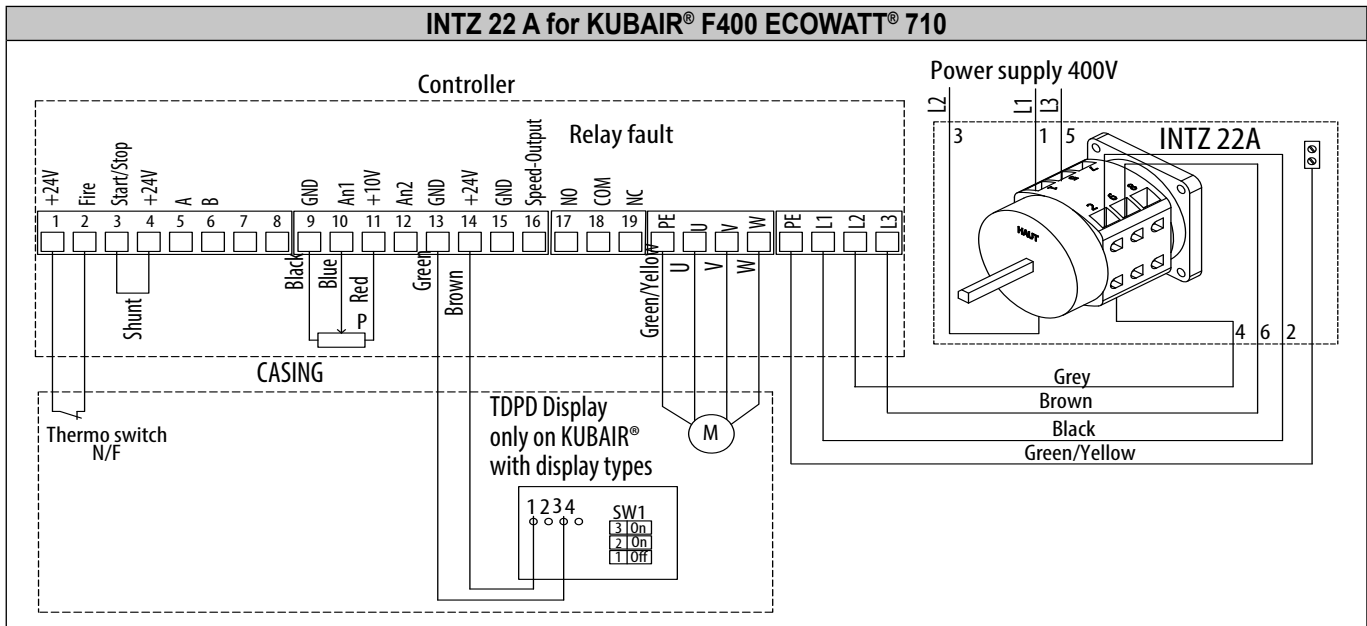
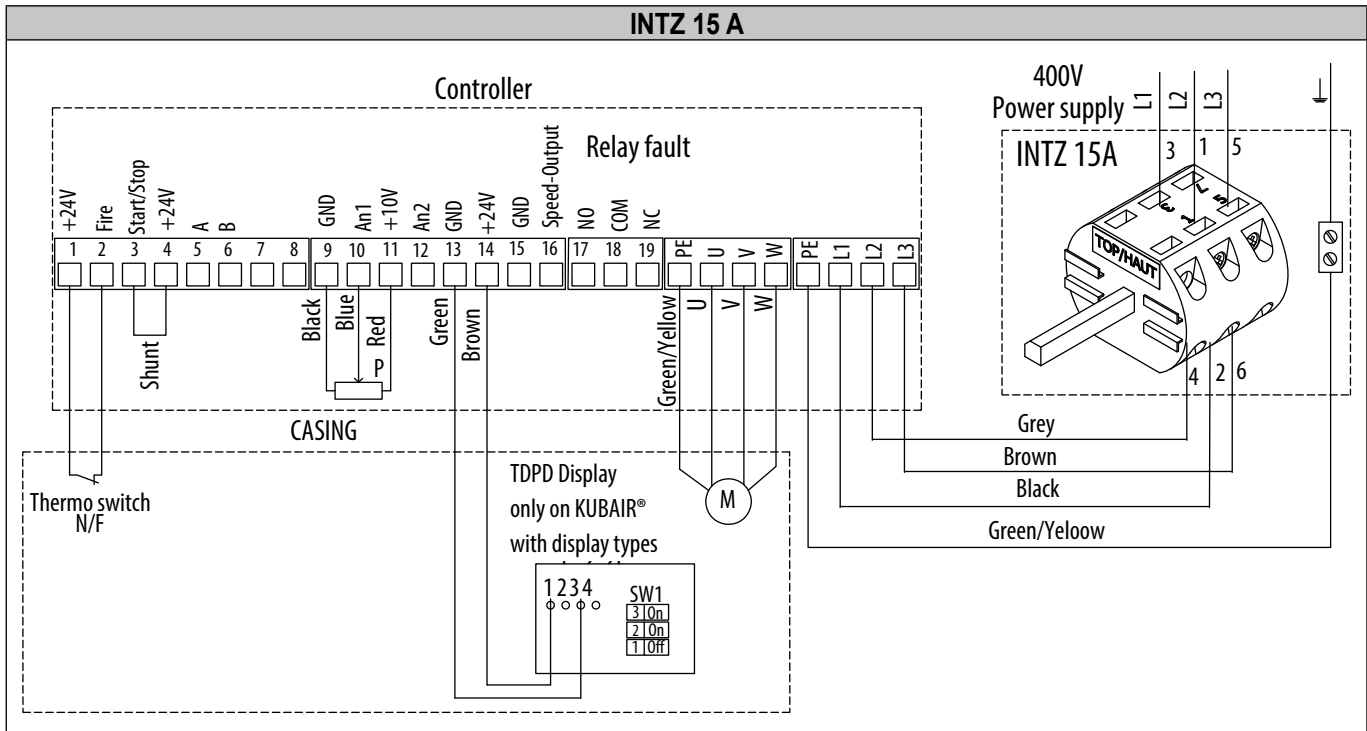

Wiring for accessories not supplied

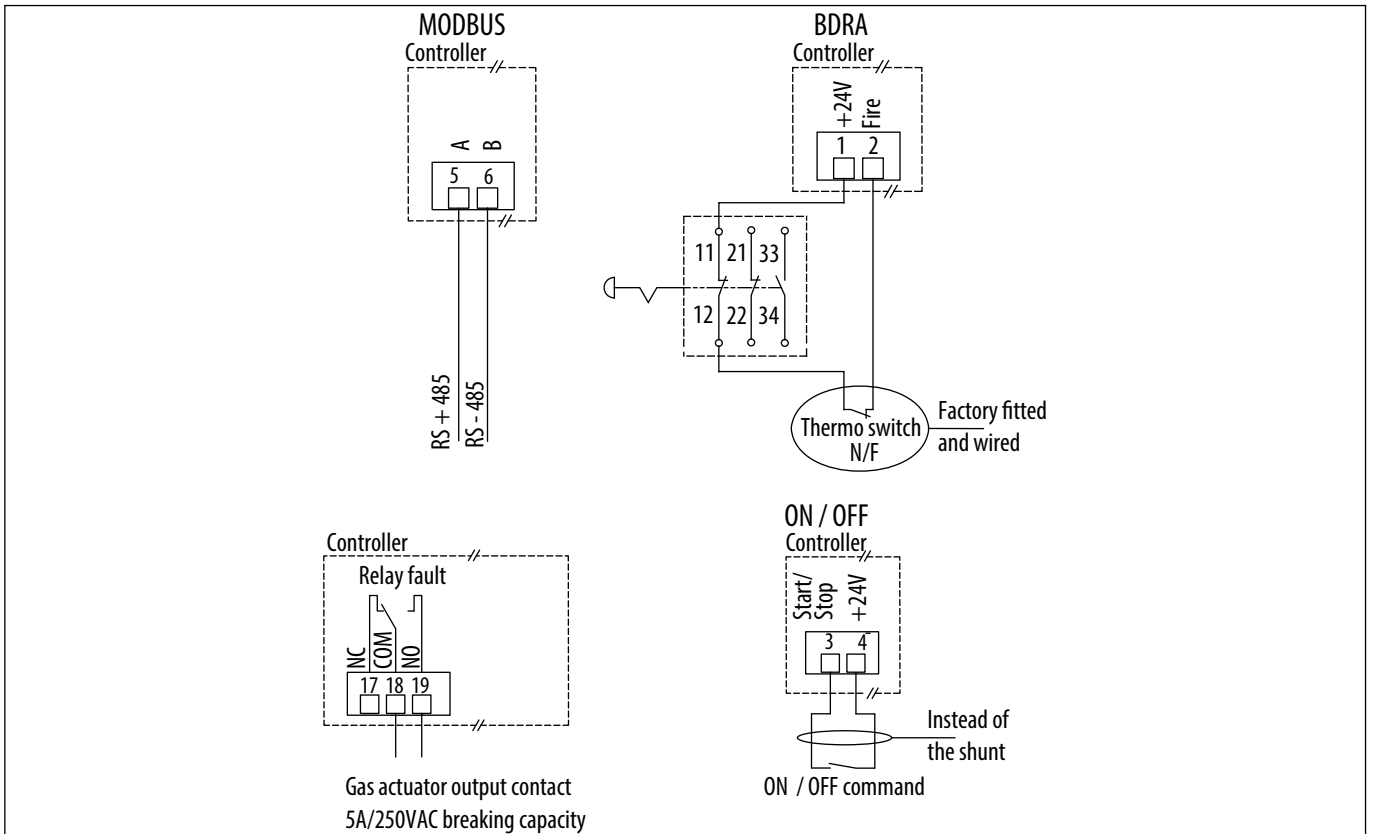

Wiring for manual adjustment and slaving to an external signal.

When the speed set point adjustment is given by the CVF type remote control, the 0-10V output or the Modbus BMS, the factory-fitted potentiometer in the controller must be disconnected.

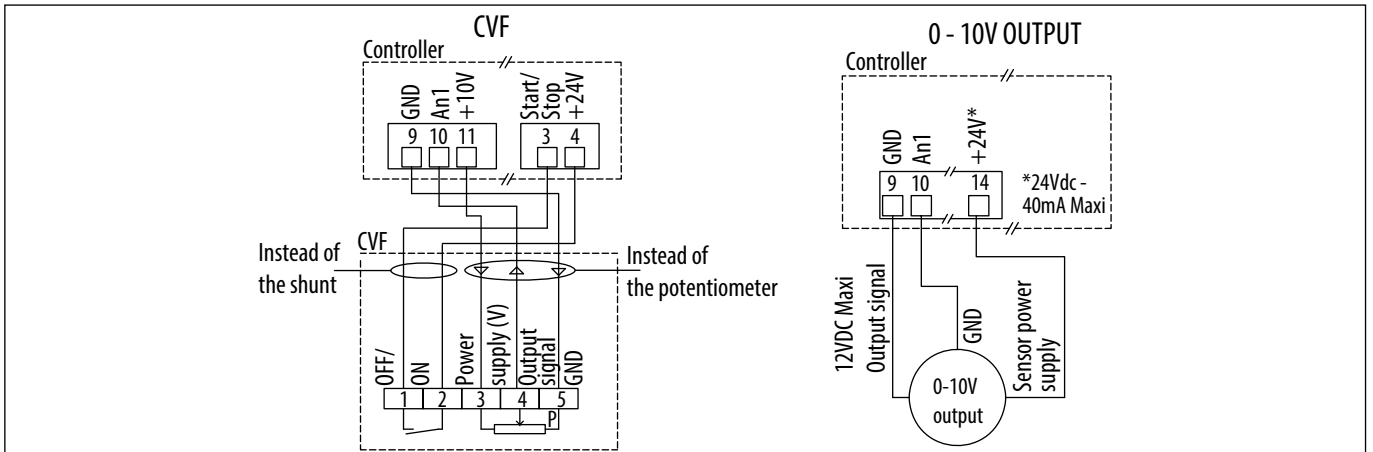

Wiring for manual two-speed control - 0-LS-HS installation diagram, with adjustable LS

The LS is defined by the potentiometer of the controller, and the HS is the speed of the roof fan on a control signal of 10V. Choice of 0-LS-HS with a BCCA type 2S switch (accessory not supplied).

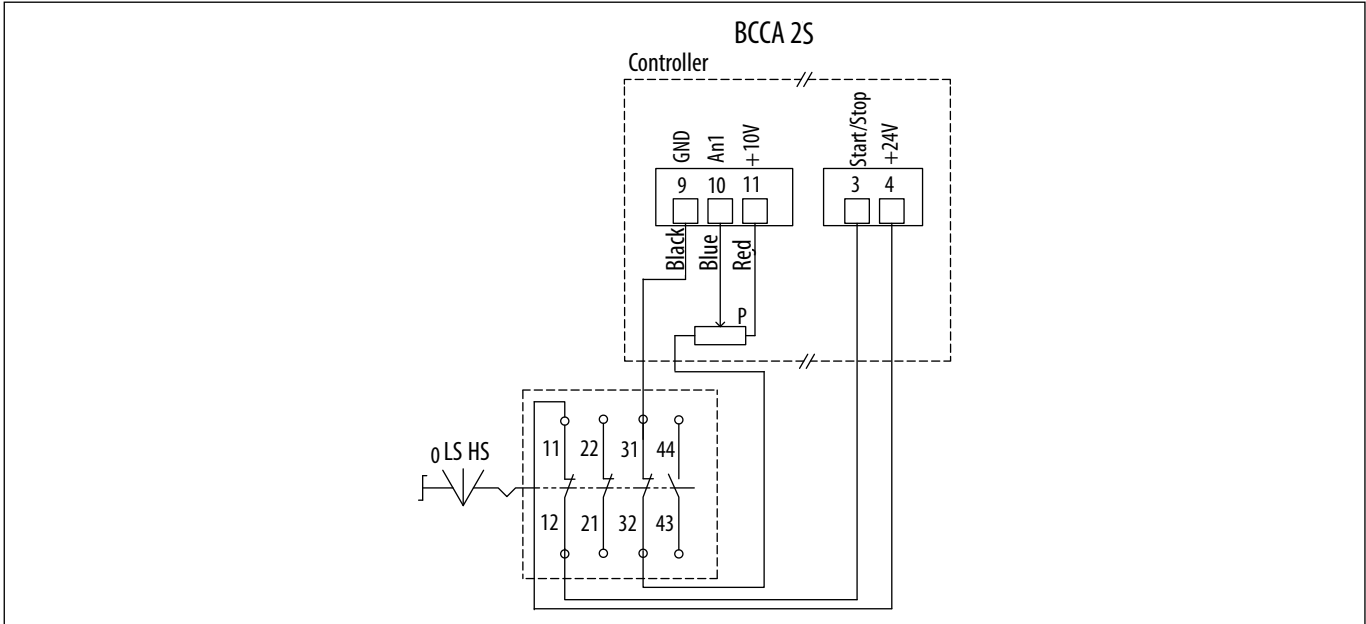

0-LS-HS installation diagram, with adjustable LS and HS

The PV and the GV are adjusted by a VRPZ VOLTAGE variator (accessory not supplied). 0-LS-HS choice with the VRPZ.

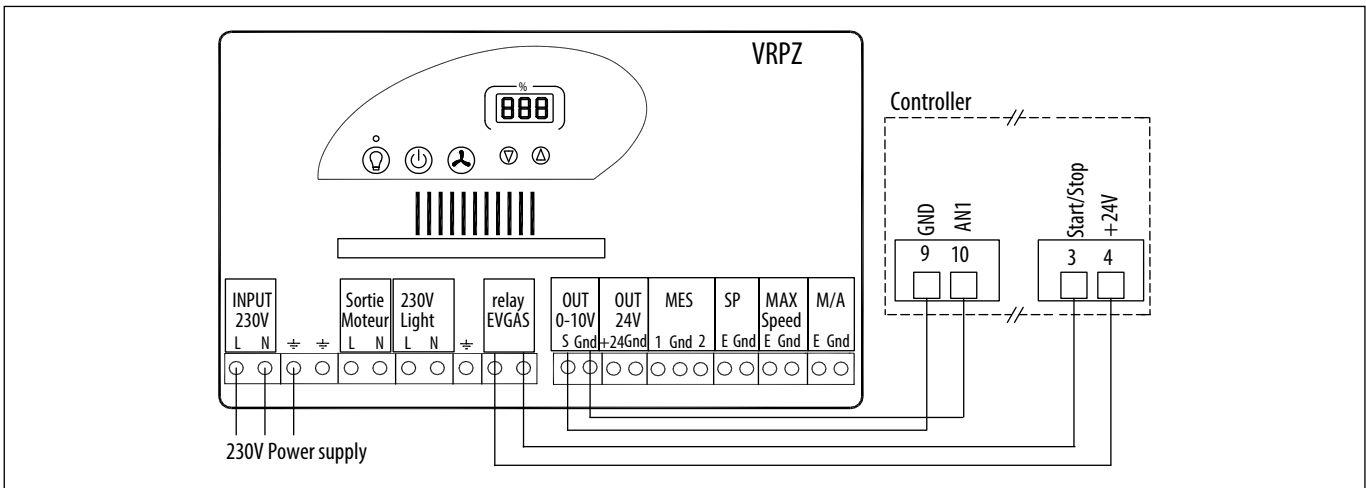

Wiring for regulation according to the deviation between the set point / external measurement

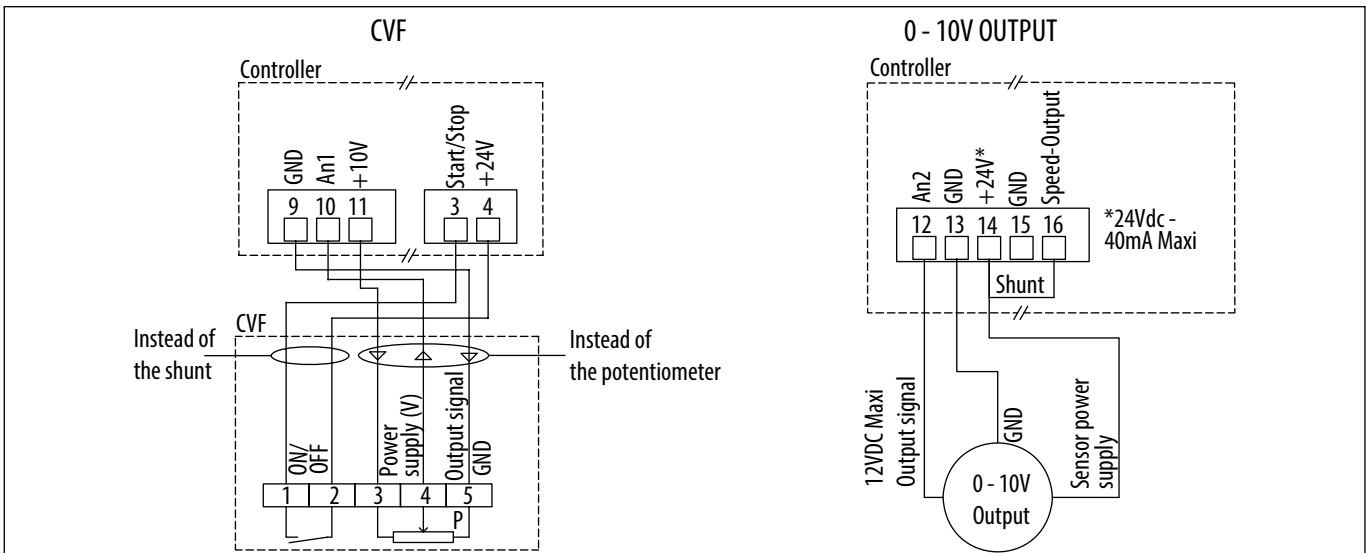

5.8.2 Speed adjustment

By potentiometer, CVF type remote control or 0-10V signal.

By default the roof fan is set to its maximum speed, in bold in the table below.

The potentiometer in the controller allows you to change the speed of the turbine to adjust the flow rate.

The adjustment can be given by the CVF type remote control or a 0-10V signal.

Correspondence table between the potentiometer graduation, the voltage applied on terminal 10 and the speed.

Graduation potentiometer	Voltage (V) at terminal 10	KUBAIR® F400 ECOWATT® 500	KUBAIR® F400 ECOWATT® 630	KUBAIR® F400 ECOWATT® 710
0	0	200 rpm	200 rpm	200 rpm
2	2	460 rpm	400 rpm	410 rpm
4	4	720 rpm	600 rpm	620 rpm
6	6	980 rpm	790 rpm	830 rpm
8	8	1 240 rpm	980 rpm	1 040 rpm
10	10	1 500 rpm	1 180 rpm	1 250 rpm

For information: The flow rate is proportional to the speed of rotation.

$$Q_{v2} = Q_{v1} \times \left(\frac{N_2}{N_1} \right) \text{ Where N is the speed of rotation.}$$

Speed adjustment 0 / LS / HS (adjustable LS)

The adjustment can be done by a BCCA type 2S 0 / LS / HS switch.

The low speed is adjusted with the controller potentiometer.

The high speed is the roof fan speed with a control signal of 10V.

Speed adjustment 0 / LS / HS (adjustable LS and HS)

The adjustment can be done with a VRPZ voltage variator.

The low speed and the high speed are adjusted with the VRPZ, see VRPZ operating instructions.

Speed adjustment by Modbus BMS

The adjustment can be done with a Modbus BMS . For the Modbus connection settings, refer to § "5.2.4 Modbus connection - Connection to a BMS".

After you have wired your Modbus link:

Turn on the power to connect yourself to the controller. The roof fan wheel must be stopped.

Steps	Register numbers	Value to be entered
1 - Access to Level 1	8	1
2 - Change in the operating mode of the controller	10	2
3 - Enabling of the on/off in Modbus	13	1
4 - Saving of changes	8	10000
5 - Changing the set point	0	Between 0 and 10,000 to set the desired speed of the roof fan, see the table below
Fan stop	13	0

Register set point 0	KUBAIR® F400 ECOWATT® 500	KUBAIR® F400 ECOWATT® 630	KUBAIR® F400 ECOWATT® 710
1000	150 rpm	120 rpm	125 rpm
2000	300 rpm	240 rpm	250 rpm
3000	450 rpm	350 rpm	375 rpm
4000	600 rpm	470 rpm	500 rpm
5000	750 rpm	590 rpm	625 rpm
6000	900 rpm	710 rpm	750 rpm
7000	1 050 rpm	830 rpm	875 rpm
8000	1 200 rpm	940 rpm	1 000 rpm
9000	1 350 rpm	1 060 rpm	1 125 rpm
10000	1 500 rpm	1 180 rpm	1 250 rpm

5.9 KUBAIR® F400 ECOWATT® 3-phases - CAV constant flow rate control

During constant flow rate operation, the controller regulates the speed of the roof fan to obtain the flow rate. A display installed under the cap indicates the flow rate measured in m³/h. The flow rate set point can be adjusted by the potentiometer in the controller, by a CAV ON/OFF + variation remote control, by an external 0-10V output or by Modbus BMS.

5.9.1 Wiring

CAV type factory assembly and wiring, with or without display. **Connection of the power supply to the INTZ switch to be done by the customer.**

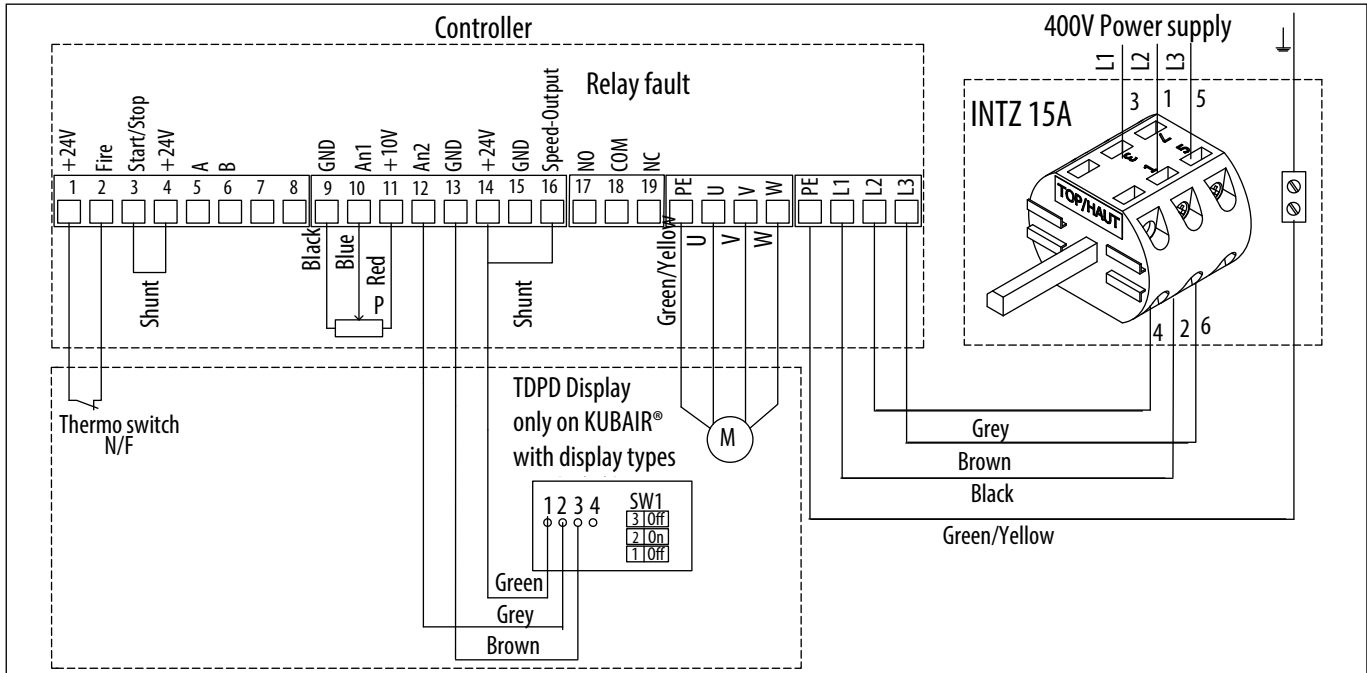

Wiring for accessories not supplied

When the flow rate set point is given by the CAV type remote control or the 0-10V output, the factory-fitted potentiometer in the controller must be disconnected.

When the speed set point is given by the MODBUS BMS the factory-fitted potentiometer in the controller must be disconnected, **as well as the shunt between terminals 14 and 16.**

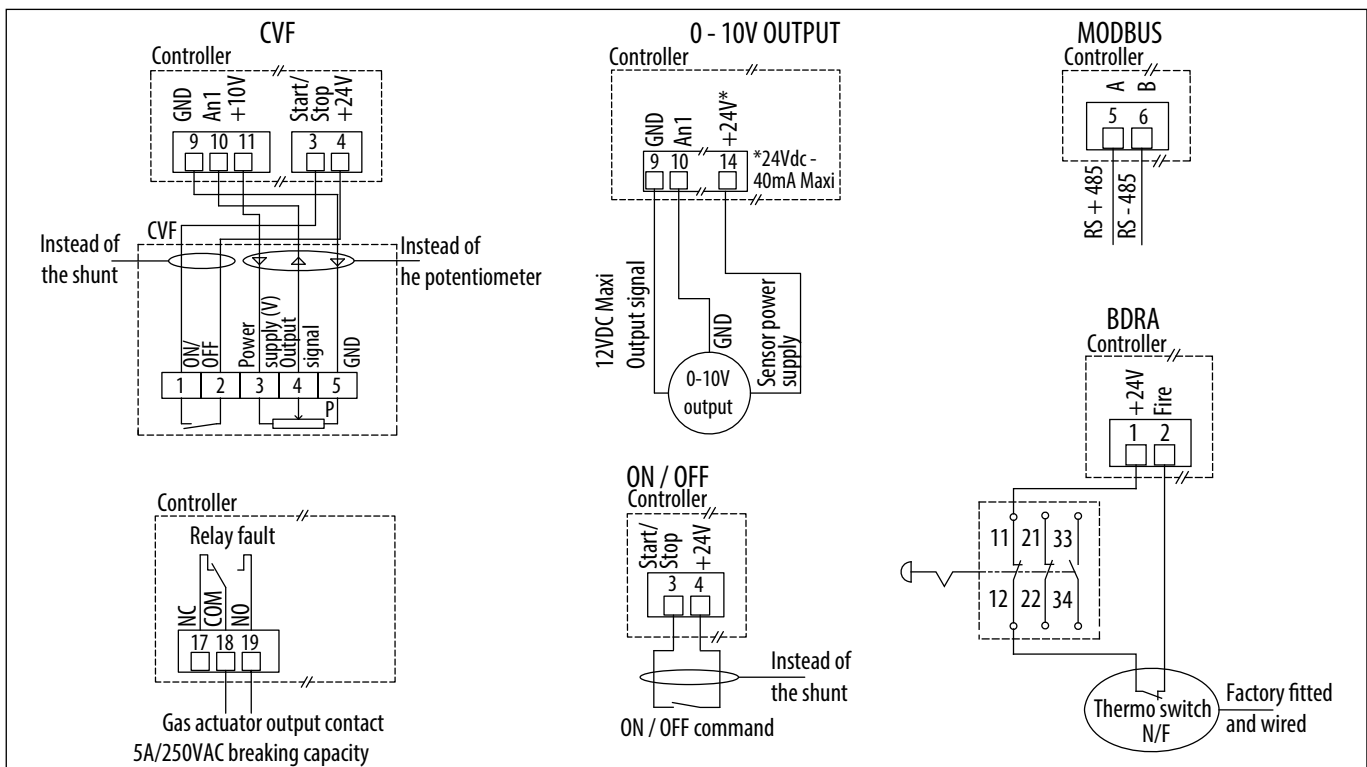

5.9.2 Adjusting the flow rate set point

By potentiometer, CVF type remote control or 0-10V output.

The potentiometer in the controller allows you to change the flow rate set point.

The set point can be given by the CVF type remote control or a 0-10V output. The display shows you the measured flow rate.

For sizes 500 / 630 / 710 : the display shows m³/h x 1000.

Graduation potentiometer	Flow rate (m ³ /h)		
	500	630	710
0	0	0	0
1	3950	6770	7480
2	5590	9570	10580
3	6850	11720	12950
4	7910	13530	14960
5	8840	15130	16720
6	9680	N/A	18320
7	10460	N/A	19790
8	N/A	N/A	21150
9	N/A	N/A	22440
10	N/A	N/A	23650

N/A : max. flow rate already reached

Note: After each adjustment wait 1 minute for the fan speed to stabilize.

By Modbus BMS

The flow rate set point can be given by a Modbus BMS set point. For the Modbus connection settings, refer to § "5.2.4 Modbus connection - Connection to a BMS".

After you have wired your Modbus link:

Turn on the power to connect yourself to the controller. The roof fan wheel must be stopped.

Steps	Register numbers	Value to be entered
1 - Access to Level 1	8	1
2 - Change in the operating mode of the controller	10	2
3 - Enabling of the on/off in Modbus	13	1
4 - Saving of changes	8	10000
5 - Changing the set point	0	Between 0 and 10,000 to define the desired flow rate set point, see the table below
Fan stop	13	0

Register set point 0	KUBAIR® F400 ECOWATT® 500	KUBAIR® F400 ECOWATT® 630	KUBAIR® F400 ECOWATT® 710
1000	3 950 m ³ /h	6 770 m ³ /h	7 480 m ³ /h
2000	5 590 m ³ /h	9 570 m ³ /h	10 580 m ³ /h
3000	6 850 m ³ /h	11 720 m ³ /h	12 950 m ³ /h
4000	7 910 m ³ /h	13 530 m ³ /h	14 960 m ³ /h
5000	8 840 m ³ /h	15 130 m ³ /h	16 720 m ³ /h
6000	9 680 m ³ /h	N/A	18 320 m ³ /h
7000	10 460 m ³ /h	N/A	19 790 m ³ /h
8000	N/A	N/A	21 150 m ³ /h
9000	N/A	N/A	22 440 m ³ /h
10000	N/A	N/A	23 650 m ³ /h

Pour information : Le débit est proportionnel à la vitesse de rotation.

$$Q_v = K \times \overline{2,5 \times \text{set point}}$$

Size of KUBAIR® F400 ECOWATT®	Coeff. K
500	250
630	428
710	473

5.10 KUBAIR® F400 ECOWATT® 3-phases - COP constant pressure control

During operation at constant pressure, the controller regulates the speed of the roof fan to obtain the set pressure. If the display is present on the roof fan, it will show you the pressure in Pa. The pressure set point can be adjusted by the potentiometer in the controller, by a CVF ON/OFF + variation remote control, by an external 0-10V output or by Modbus BMS.

5.10.1 Wiring

COP type factory assembly and wiring, with or without display. **Connection of the power supply to the INTZ switch to be done by the customer.**

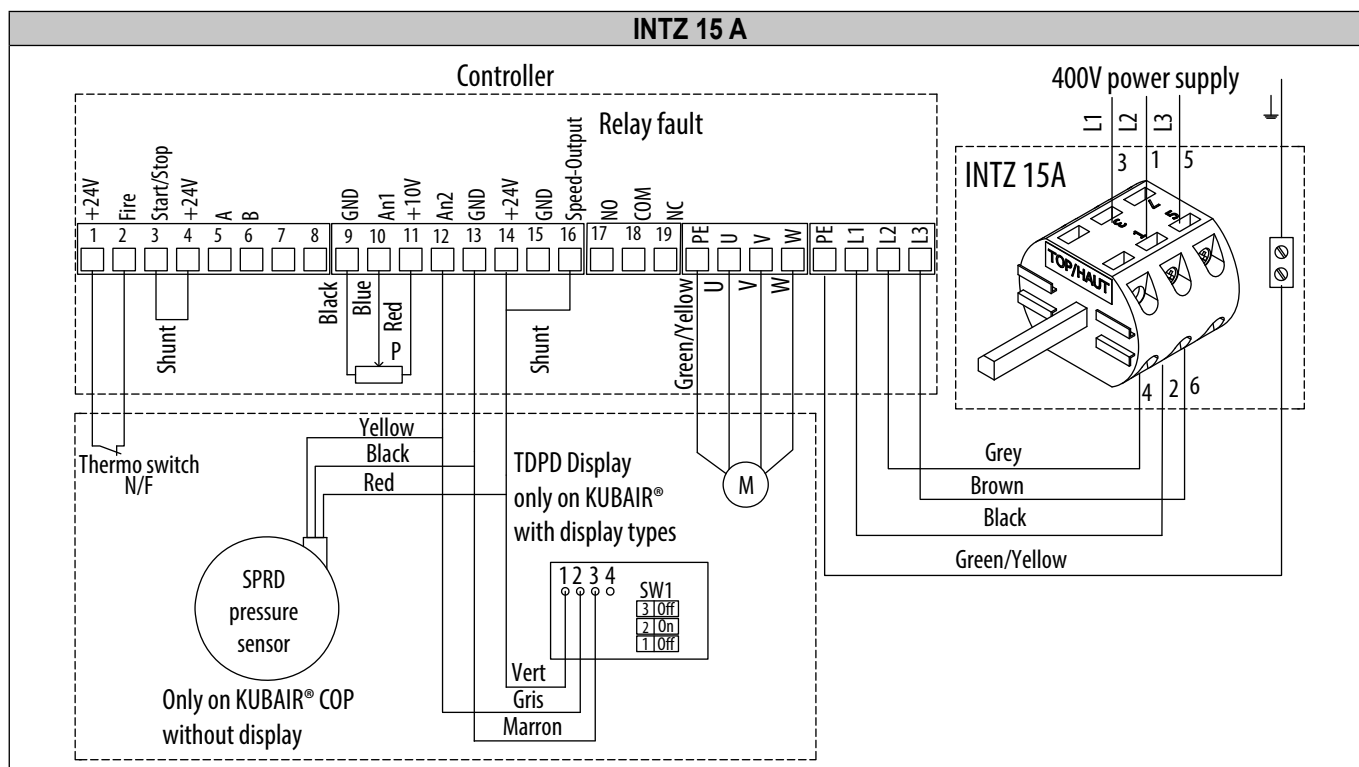

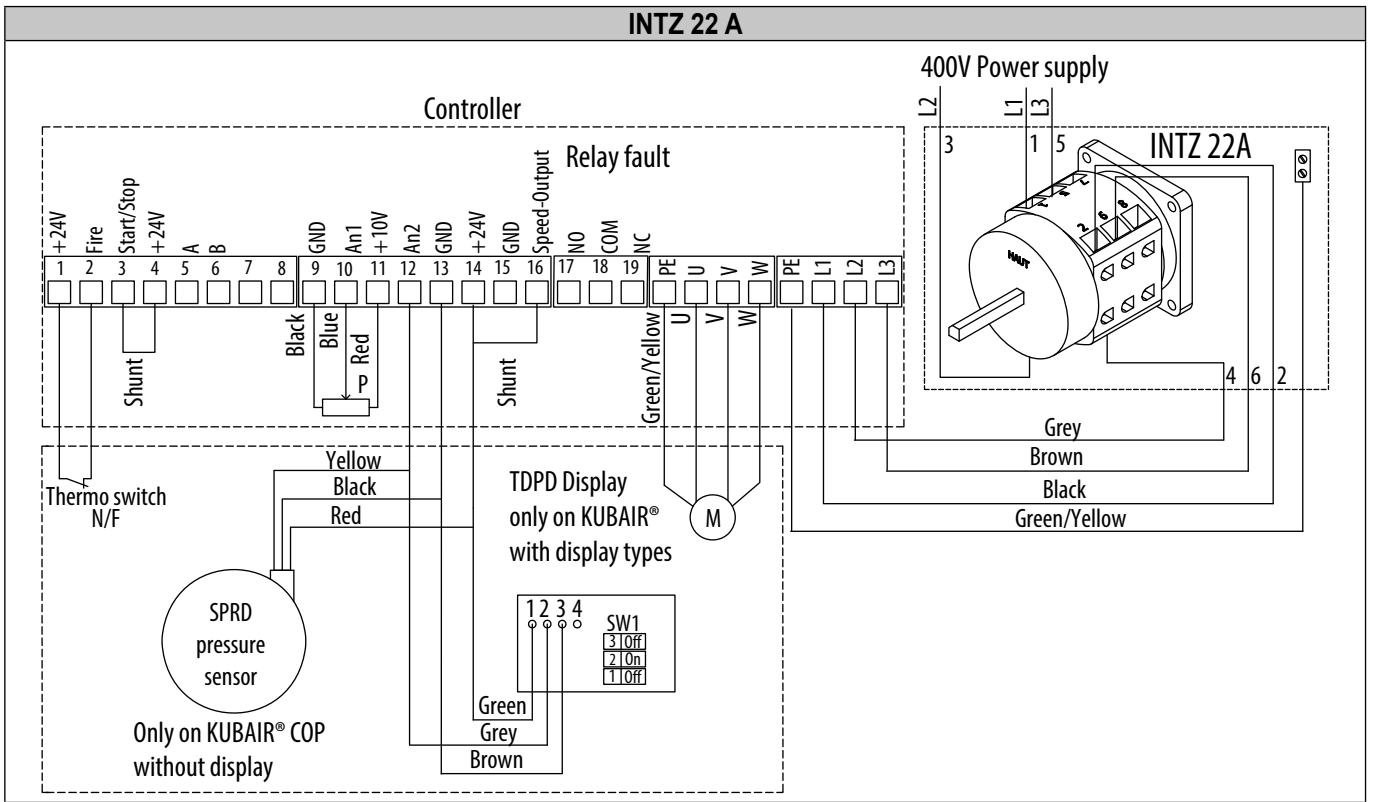

Wiring for accessories not supplied

When the pressure set point is given by the CVF type remote control or the 0-10V output, the factory-fitted potentiometer in the controller must be disconnected.

When the speed set point is given by the MODBUS BMS the factory-fitted potentiometer in the controller must be disconnected, **as well as the shunt between terminals 14 and 16.**

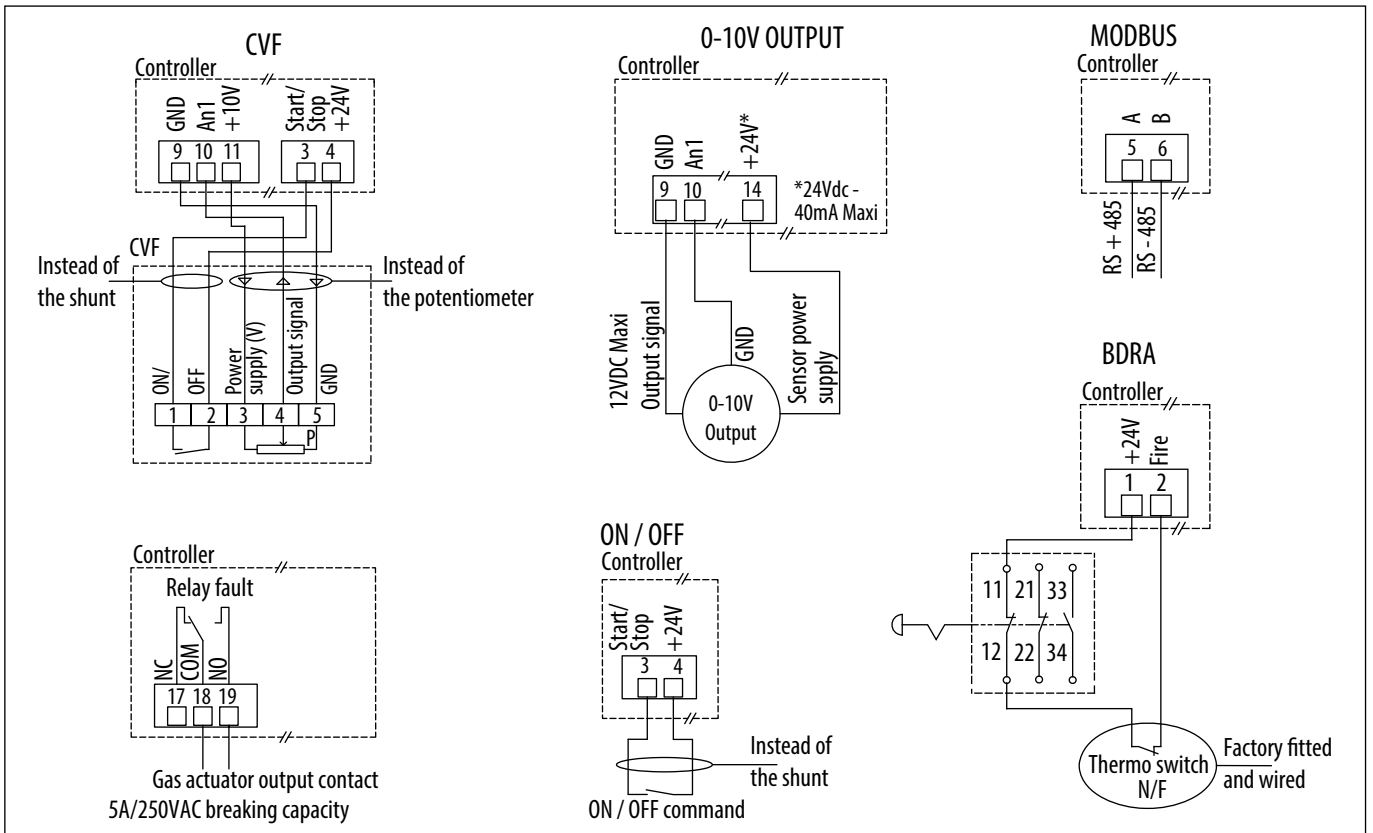

5.10.2 Adjusting the pressure set point

By potentiometer, CVF type remote control or 0-10V output.

By default the roof fan is set to obtain the pressure in bold in the table.

The potentiometer in the controller allows you to change the pressure set point.

The set point can be given by the CVF type remote control or a 0-10V output.

Correspondence table between the potentiometer graduation, the voltage applied on terminal 10 and the pressure set point.

Graduation potentiometer	Voltage (V) at terminal 10	Without display	With display
1	1	100 Pa	160 Pa
2	2	300 Pa	320 Pa
3	3	500 Pa	480 Pa
4	4	700 Pa	640 Pa
5	5	800 Pa	800 Pa
6	6	800 Pa	960 Pa
7	7	800 Pa	1 120 Pa
8	8	800 Pa	1 280 Pa
9	9	800 Pa	1 440 Pa
10	10	800 Pa	1 600 Pa

If the roof fan has a display, the display will show you the pressure measured at the roof fan plate (see diagram below).

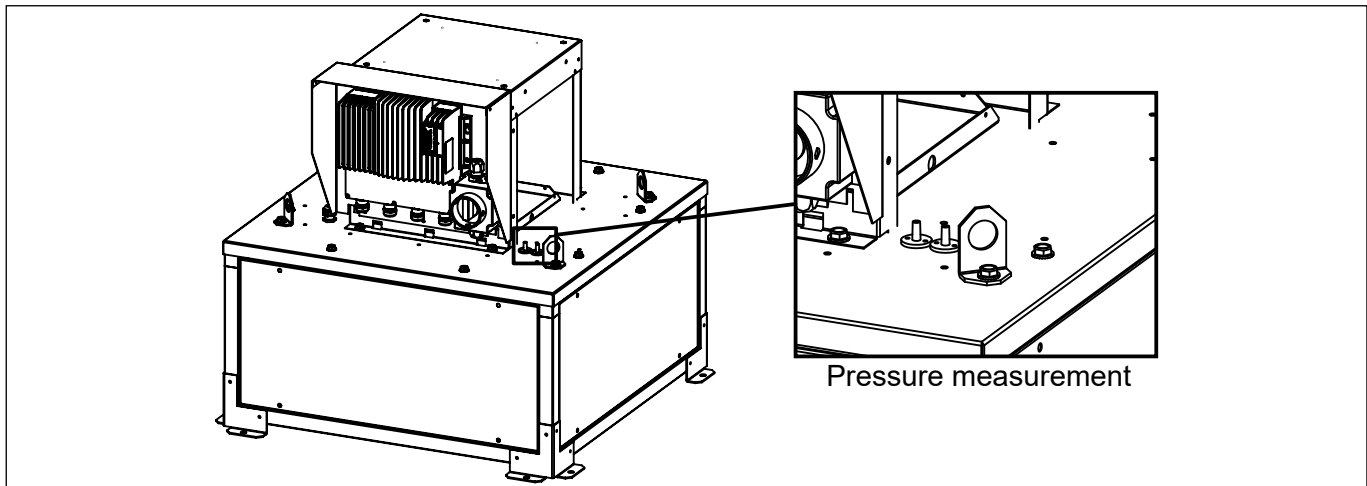

Note: After each adjustment wait 1 minute for the fan speed to stabilize.

By Modbus BMS

The pressure set point can be given by a Modbus BMS set point. For the Modbus connection settings, refer to §"5.2.4 Modbus connection - Connection to a BMS".

After you have wired your Modbus link:

Turn on the power to connect yourself to the controller. The roof fan wheel must be stopped.

Modbus register table:

Steps	Register numbers	Value to be entered
1 - Access to Level 1	8	1
2 - Change in the operating mode of the controller	10	2
3 - Enabling of the on/off in Modbus	13	1
4 - Saving of changes	8	10000
5 - Changing the set point	0	Between 0 and 10,000 to define the desired pressure set point, see the table below
Fan stop	13	0

Without display	
Register set point 0	Pressure (Pa)
1 000	100
2 000	300
3 000	500
4 000	700
4 500	800
4 500 à 10 000	800

With display	
Register set point 0	Pressure (Pa)
100	160
200	320
300	480
400	640
500	800
600	960
700	1 120
800	1 280
900	1 440
1000	1 600

6. MAINTENANCE

The maintenance frequency depends on the operating conditions. If the air is highly loaded with impurities, the duration between two visits must be shortened.

WARNING: Before any maintenance operation, cut off the power supply upstream of the casing and make sure that it cannot be re-established during the intervention (lockout).

The motors used do not require any particular maintenance. They are fitted with sealed greased-for-life ball bearings.

6.1 Maintenance frequency

Perform a periodical check based on the following indications:

Unit/Item	At commissioning	Every 6 months minimum
Turbine	Check the direction of rotation and the absence of friction between the moving parts and the fixed parts	Clean if necessary, check the absence of friction between the moving parts and the fixed parts
Controller	Check the connections, especially those to earth	Retighten the terminals if necessary, check the rated current
Switch	Check the connections, especially those to earth	Tighten the terminals if necessary
Protective grilles	Check the presence	Clean if necessary
Duct networks	Check the sealing	Clean if necessary
Fastenings	Check the tightness	Tighten the screws if necessary
Pressure tapping	Check the aeraulic connections	Check the operation

6.2 Spare parts KUBAIR® F400 ECOWATT®

Model	Code	Designation
KUBAIR® F400 ECOWATT® 355 Mono 230V	646890	MTTE KUBAIR® ECOWATT® 355 Mono 230V Spare motor-fan
KUBAIR® F400 ECOWATT® 400 Mono 230V	646891	MTTE KUBAIR® ECOWATT® 400 Mono 230V Spare motor-fan
KUBAIR® F400 ECOWATT® 450® Mono 230V	646890	MTTE KUBAIR® ECOWATT® 450 Mono 230V Spare motor-fan
KUBAIR® F400 ECOWATT® 500 Tri 400V	646891	MTTE KUBAIR® ECOWATT® 500 Tri 400V Spare motor-fan
KUBAIR® F400 ECOWATT® 630 Tri 400V	646890	MTTE KUBAIR® ECOWATT® 630 Tri 400V Spare motor-fan
KUBAIR® F400 ECOWATT® 710 Tri 400V	646891	MTTE KUBAIR® ECOWATT® 710 Tri 400V Mototurbine recharge
KUBAIR® F400 ECOWATT® 355	157112	COMPACTO 08 - KUBAIR® ECOWATT® 355
KUBAIR® F400 ECOWATT® 400	157113	COMPACTO 08 - KUBAIR® ECOWATT® 400
KUBAIR® F400 ECOWATT® 450	157114	COMPACTO 11 - KUBAIR® ECOWATT® 450
KUBAIR® F400 ECOWATT® 500	157116	INVENTO S15 - KUBAIR® ECOWATT® 500
KUBAIR® F400 ECOWATT® 630	157118	INVENTO S30 - KUBAIR® ECOWATT® 630
KUBAIR® F400 ECOWATT® 710	157119	INVENTO S55 - KUBAIR® ECOWATT® 710
KUBAIR® F400 ECOWATT® 355 to 710	132149	Potentiometer card
KUBAIR® F400 ECOWATT® 355 to 630	700800	INTZ 1V15
KUBAIR® F400 ECOWATT® 710	700801	INTZ 1V22
KUBAIR® F400 ECOWATT® 355 to 710	132078	TDPD

7. WASTE MANAGEMENT

7.1 Treatment of Packagings and non dangerous wastes

The packagings (unconsigned pallets, cartons, films, wooden boxes) and other non dangerous wastes must be made reusable by an approved service provider. It is strictly prohibited to burn, bury or dump them in nature.

7.2 Treatment of a Professional WEEE

This product must not be dumped or treated with household refuse, but must be deposited in an appropriate collection point for waste electrical and electronic equipment (WEEE).

Document not contractual. Constantly concerned about improving his equipment, the manufacturer reserves the right to make all technical changes without notice.

VIM

Les prés de Mégy Sud – SOUDAN

CS 60120 - 79401 ST MAIXENT L'ECOLE CEDEX

Tél. : 05 49 06 60 38 ou 05 49 06 60 25 – Fax : 05 49 06 60 36

sav@vim.fr - www.vim.fr